

CLUTCH

SECTION **CL**

CONTENTS

PRECAUTIONS	2	CLUTCH RELEASE MECHANISM	10
Precautions	2	Components.....	10
PREPARATION	3	Removal and Installation	10
Special Service Tools	3	Inspection.....	11
Commercial Service Tools	3	Lubrication	11
NOISE, VIBRATION AND HARSHNESS (NVH)		Waterproof - for 4WD Model	11
TROUBLESHOOTING	4	CLUTCH DISC, CLUTCH COVER AND	
NVH Troubleshooting Chart.....	4	FLYWHEEL	12
CLUTCH	4	Components.....	12
CLUTCH SYSTEM - HYDRAULIC TYPE	5	Inspection and Adjustment	12
Components.....	5	CLUTCH DISC.....	12
Inspection and Adjustment	6	CLUTCH COVER AND FLYWHEEL.....	13
ADJUSTING CLUTCH PEDAL	6	FLYWHEEL INSPECTION	13
AIR BLEEDING PROCEDURE	7	Installation.....	13
CLUTCH MASTER CYLINDER	8	SERVICE DATA AND SPECIFICATIONS (SDS)	14
Components.....	8	Clutch Control System.....	14
Disassembly and Assembly.....	8	Clutch Master Cylinder (with clutch damper)	14
Inspection.....	8	Clutch Operating Cylinder	14
OPERATING CYLINDER	9	Clutch Disc.....	14
Components.....	9	Clutch Cover	14
Inspection.....	9	Clutch Pedal	14

GI

MA

EM

LC

EC

FE

CL

MT

AT

TF

PD

AX

SU

BR

ST

RS

BT

HA

SC

EL

IDX

PRECAUTIONS

Precautions

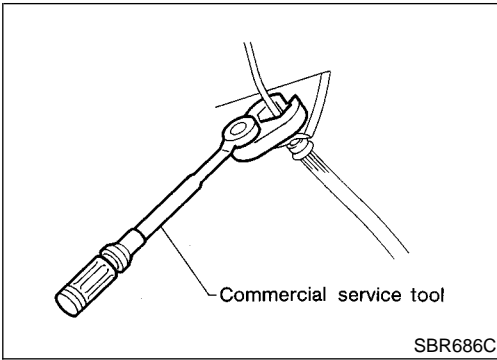

Precautions

NGCL0001

- Recommended fluid is brake fluid "DOT 3".
- Never reuse drained brake fluid.
- Be careful not to splash brake fluid on painted areas.
- When removing and installing clutch piping, use Tool.
- Use new brake fluid to clean or wash all parts of master cylinder, operating cylinder, and clutch damper.
- Never use mineral oils such as gasoline or kerosene. It will ruin the rubber parts of the hydraulic system.

WARNING:

After cleaning the clutch disc, wipe it with a dust collector. Do not use compressed air.

PREPARATION

Special Service Tools

Special Service Tools

NGCL0002

The actual shapes of Kent-Moore tools may differ from those of special service tools illustrated here.

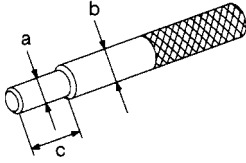
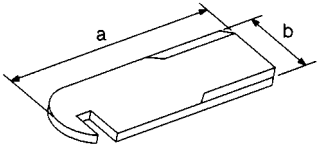
Tool number (Kent-Moore No.) Tool name	Description	
ST20630000 (J26366) Clutch aligning bar		Installing clutch cover and clutch disc a: 15.9 mm (0.626 in) dia. b: 22.8 mm (0.898 in) dia. c: 55 mm (2.17 in)
ST20050240 (—) Diaphragm spring adjusting wrench		Adjusting unevenness of diaphragm spring of clutch cover a: 150 mm (5.91 in) b: 25 mm (0.98 in)

Commercial Service Tools

NGCL0003

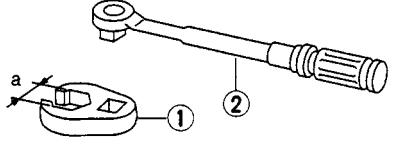
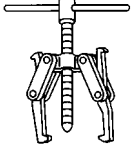
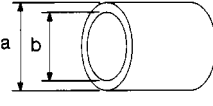
Tool name	Description	
1 Flare nut crowfoot 2 Torque wrench		Removing and installing clutch piping a: 10 mm (0.39 in)
Bearing puller		Removing release bearing
Bearing drift		Installing release bearing a: 52 mm (2.05 in) dia. b: 45 mm (1.77 in) dia.

GI
MA
EM
LC
EC
FE
CL
MT
AT
TF
PD
AX
SU
BR
ST
RS
BT
HA
SC
EL
IDX

NOISE, VIBRATION AND HARSHNESS (NVH) TROUBLESHOOTING

NVH Troubleshooting Chart

NVH Troubleshooting Chart

NGCL0027S01

Use the chart below to help you find the cause of the problem. The numbers indicate the priority of the likely cause of the problem. Check each part in order. If necessary, repair or replace these parts.

CLUTCH

NGCL0027S0101

Reference page	CL-6	CL-7	CL-8	CL-9	EM-41, EM-100	CL-10	CL-12	CL-12	CL-12	CL-12	CL-12	CL-12	CL-12	CL-12	CL-12	CL-13	CL-13	CL-13	CL-13
SUSPECTED PARTS (Possible cause)	CLUTCH PEDAL (Free play out of adjustment)	CLUTCH LINE (Air in line)	MASTER CYLINDER PISTON CUP (Damaged)	OPERATING CYLINDER PISTON CUP (Damaged)	ENGINE MOUNTING (Loose)	RELEASE BEARING (Worn, dirty or damaged)	CLUTCH DISC (Out of true)	CLUTCH DISC (Runout is excessive)	CLUTCH DISC (Lining broken)	CLUTCH DISC (Dirty or burned)	CLUTCH DISC (Oily)	CLUTCH DISC (Worn out)	CLUTCH DISC (Hardened)	CLUTCH DISC (Lack of spline grease)	DIAPHRAGM SPRING (Damaged)	DIAPHRAGM SPRING (Out of tip alignment)	PRESSURE PLATE (Distortion)	FLYWHEEL (Distortion)	
Symptom	Clutch grabs/chatters				1			2			2	2	2				2		
	Clutch pedal spongy		1	2	2														
	Clutch noisy					1													
	Clutch slips	1									2	2			3		4	5	
	Clutch does not disengage	1	2	3	4		5	5	5	5	5			5	6	6	7		

CLUTCH SYSTEM — HYDRAULIC TYPE

Components

Components

NGCL0004

SEC. 300 • 305 • 306 • 465

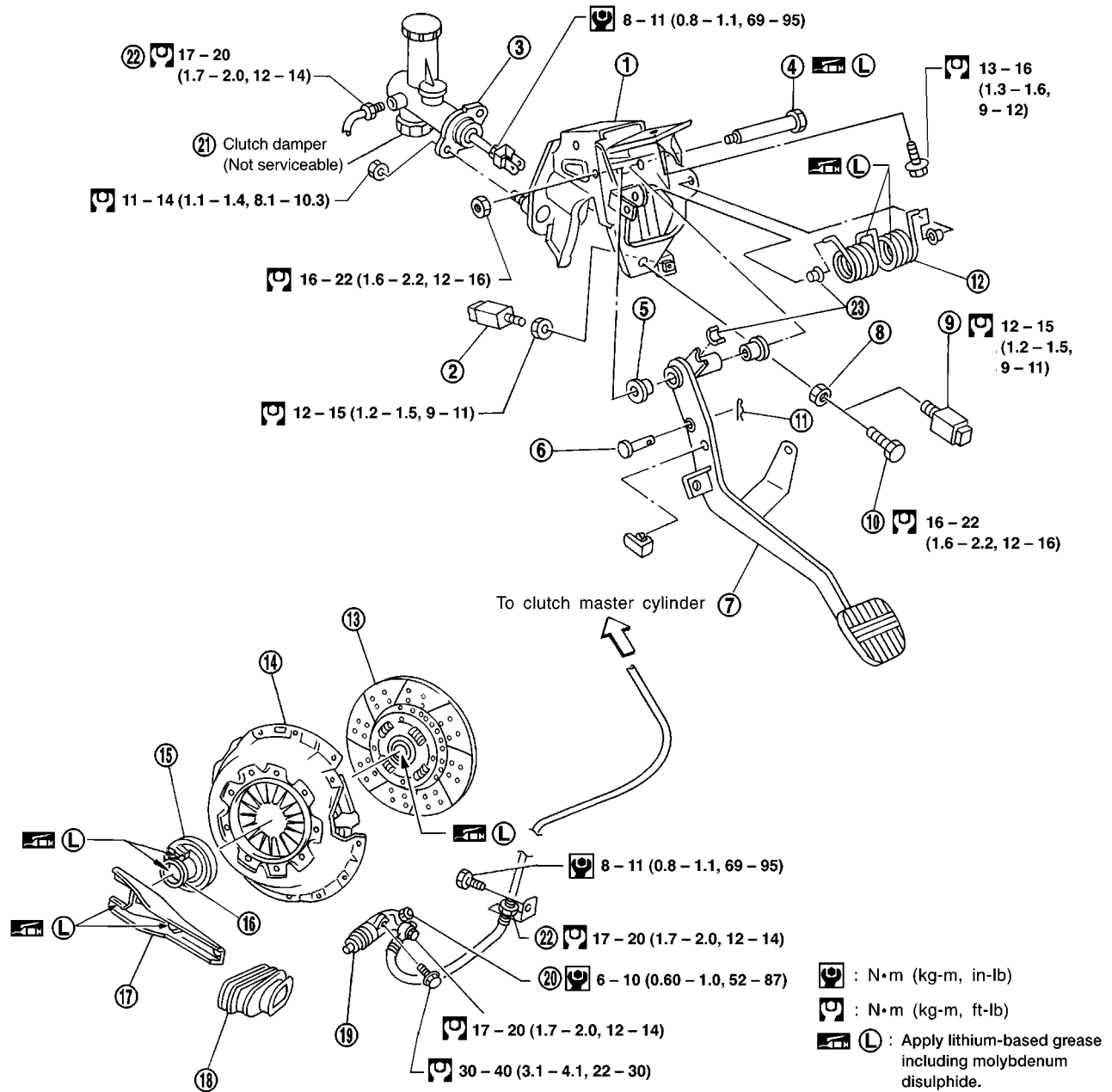

ACL106

- | | | |
|----------------------------|----------------------------|------------------------|
| 1. Clutch pedal bracket | 9. ASCD cancel switch | 17. Withdrawal lever |
| 2. Clutch interlock switch | 10. Pedal stopper | 18. Dust boot |
| 3. Clutch master cylinder | 11. Snap pin | 19. Operating cylinder |
| 4. Fulcrum pin | 12. Assist spring | 20. Air bleeder |
| 5. Bushing | 13. Clutch disc | 21. Clutch damper |
| 6. Clevis pin | 14. Clutch cover | 22. Flare nut |
| 7. Clutch pedal | 15. Release bearing | 23. Bushing |
| 8. Lock nut | 16. Release bearing sleeve | |

GI
MA
EM
LC
EC
FE
CL
MT
AT
TF
PD
AX
SU
BR
ST
RS
BT
HA
SC
EL
IDX

CLUTCH SYSTEM — HYDRAULIC TYPE

Inspection and Adjustment

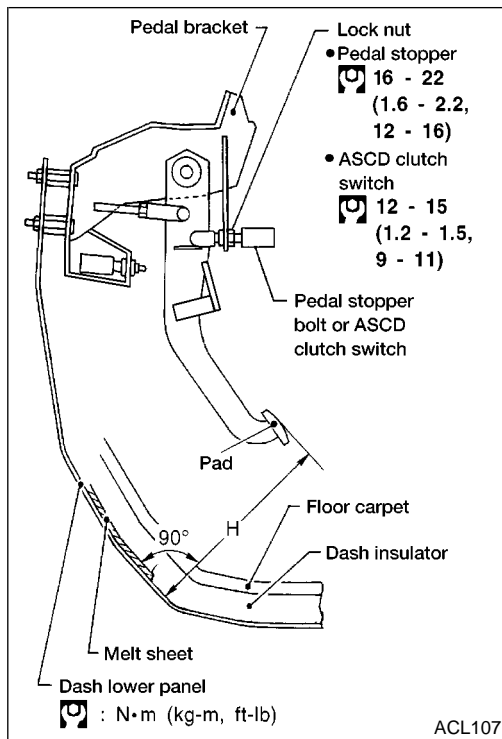

Inspection and Adjustment

ADJUSTING CLUTCH PEDAL

NGCL0005

NGCL0005S01

1. Adjust pedal height with pedal stopper or ASCD cancel switch.

Pedal height "H":

KA24DE: 221 – 231 mm (8.70 – 9.09 in)

VG33E: 227 – 237 mm (8.94 – 9.33 in)

2. Adjust pedal free play with master cylinder push rod. Then tighten lock nut.

Pedal free play (measured at pedal pad) "A":

9 - 16 mm (0.35 - 0.63 in)

Pedal free play means the following total measured at position of pedal pad:

- Play due to clevis pin, clevis pin hole in clutch pedal and master cylinder.
3. Make sure that clevis pin can rotate smoothly. If not, readjust pedal free play with master cylinder push rod.

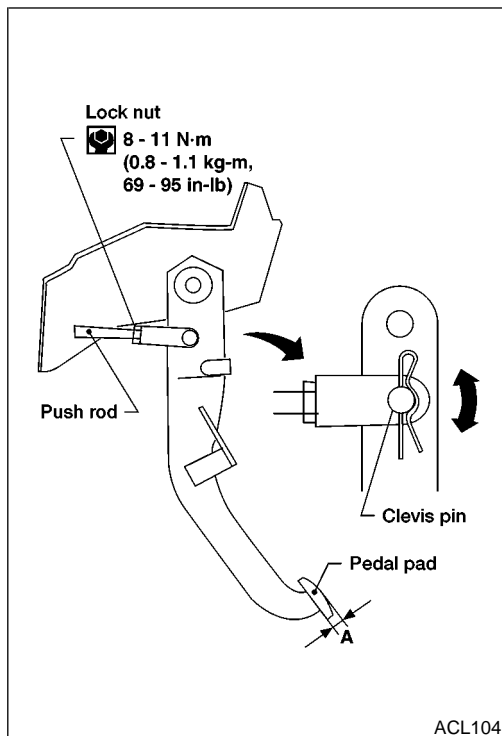

CLUTCH SYSTEM — HYDRAULIC TYPE

Inspection and Adjustment (Cont'd)

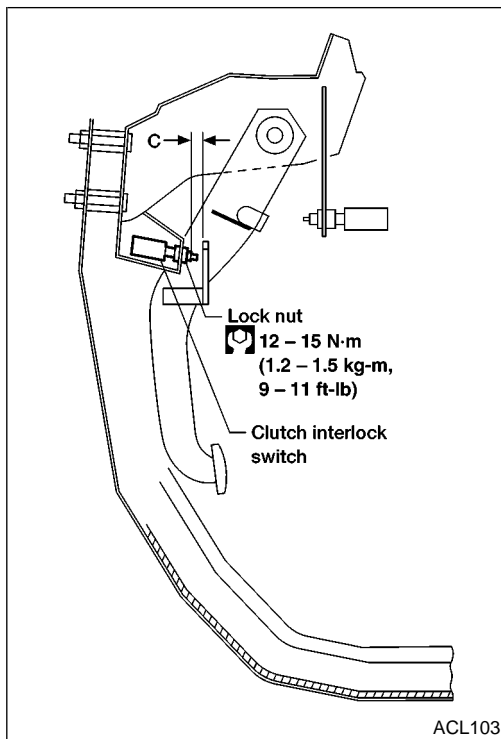

— Models with Clutch Interlock System —

NGCL0005S0101

1. Adjust clearance "C" shown in the figure while fully depressing clutch pedal.

Clearance C:

0.1 - 1.0 mm (0.004 - 0.039 in)

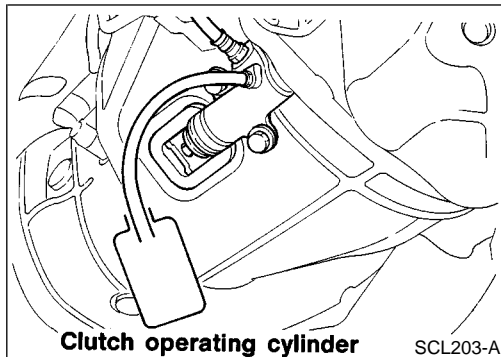

AIR BLEEDING PROCEDURE

NGCL0005S02

Bleed air according to the following procedure.

Bleed air from operating cylinder.

- 1) Fill the master cylinder reservoir tank with new brake fluid.
- 2) Connect a transparent vinyl hose to the air bleeder.
- 3) Slowly depress the clutch pedal to its full stroke length and release it completely. Repeat this operation several times at 2 to 3 second intervals.
- 4) Open the air bleeder with the clutch pedal fully depressed.
- 5) Close the air bleeder.
- 6) Release the clutch pedal and wait at least 5 seconds.
- 7) Repeat steps 3 through 6 above until air bubbles no longer appear in the brake fluid

GI

MA

EM

LC

EC

FE

CL

MT

AT

TF

PD

AX

SU

BR

ST

RS

BT

HA

SC

EL

IDX

CLUTCH MASTER CYLINDER

Components

Components

NGCL0006

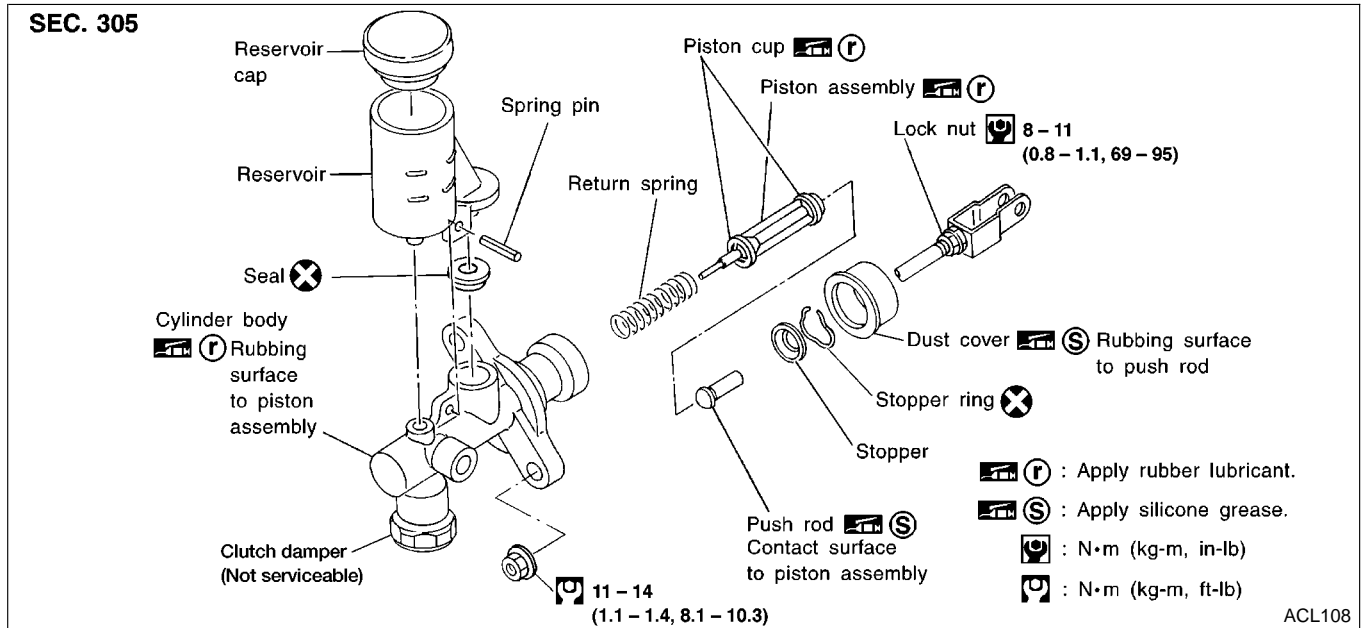

Disassembly and Assembly

NGCL0007

- Use a screwdriver to remove stopper ring while pushing push rod into cylinder.
- When installing stopper ring, tap in lightly while pushing push rod into cylinder.

Inspection

NGCL0008

Check the following items, and replace if necessary.

- Rubbing surface of cylinder and piston, for uneven wear, rust, or damage
- Piston with piston cup, for wear or damage
- Return spring, for wear or damage
- Dust cover, for cracks, deformation, or damage
- Reservoir, for deformation or damage

Components

NGCL0009

SEC. 306

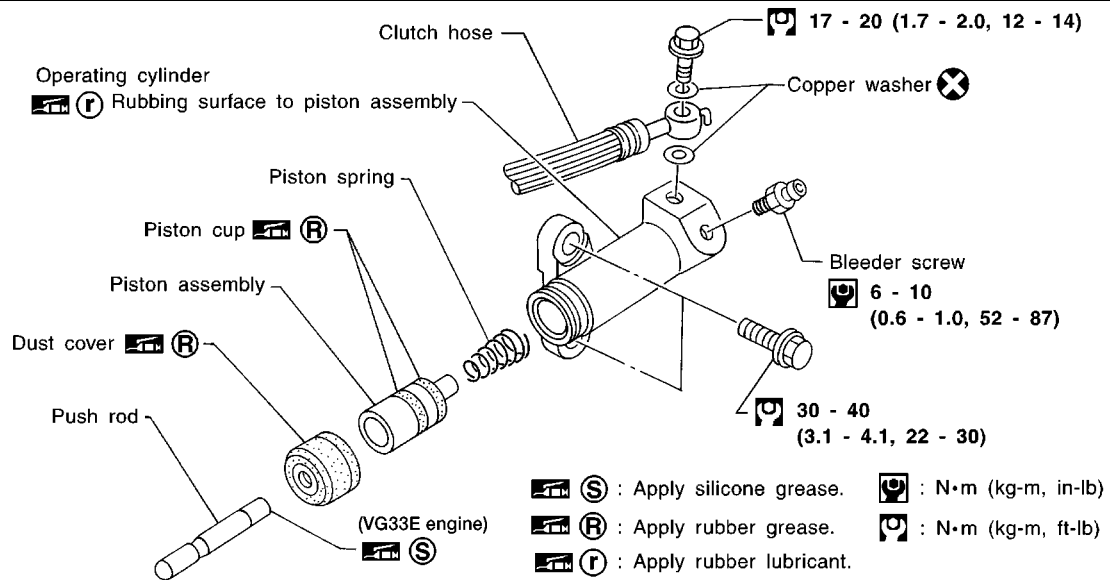

ACL109

Inspection

NGCL0010

Check the following items, and replace if necessary.

- Rubbing surface of cylinder and piston, for uneven wear, rust, or damage
- Piston with piston cup, for wear or damage
- Piston spring, for wear or damage
- Dust cover, for cracks, deformation, or damage

GI

MA

EM

LC

EC

FE

CL

MT

AT

TF

PD

AX

SU

BR

ST

RS

BT

HA

SC

EL

IDX

CLUTCH RELEASE MECHANISM

Components

Components

NGCL0013

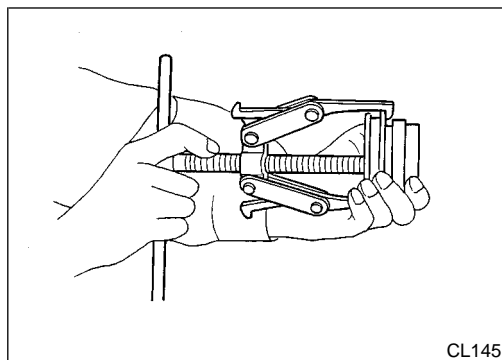
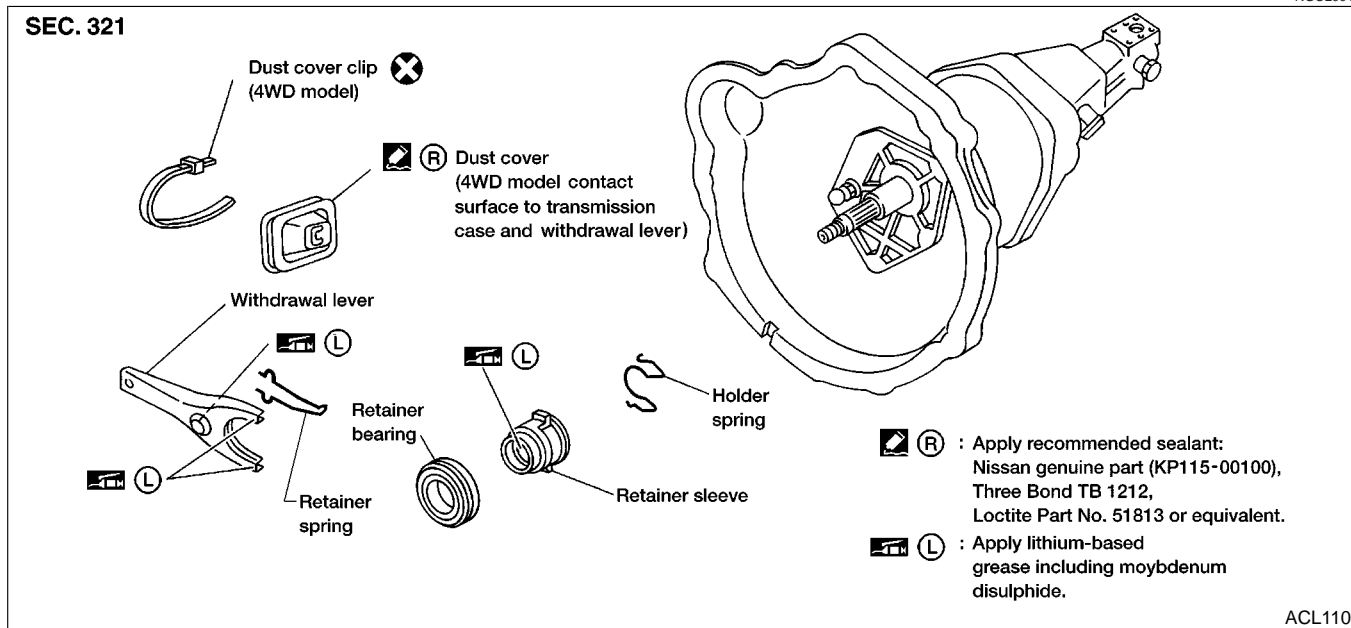

Removal and Installation

NGCL0014

- Remove release bearing.
- Install release bearing with suitable drift.
- Install retainer spring and holder spring.

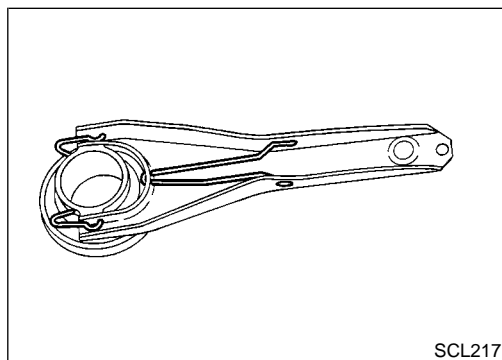
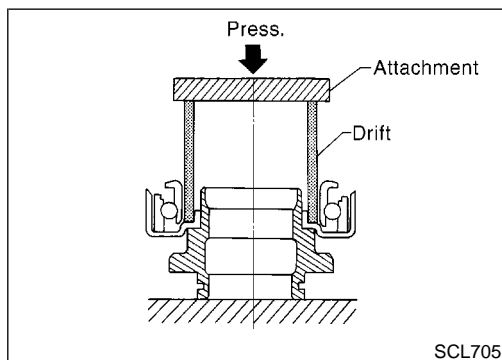

CLUTCH RELEASE MECHANISM

Inspection

Inspection

NGCL0015

Check the following items, and replace if necessary.

- Release bearing, to see that it rolls freely and is free from noise, cracks, pitting, or wear.
- Release sleeve and withdrawal lever rubbing surface, for wear, rust, or damage

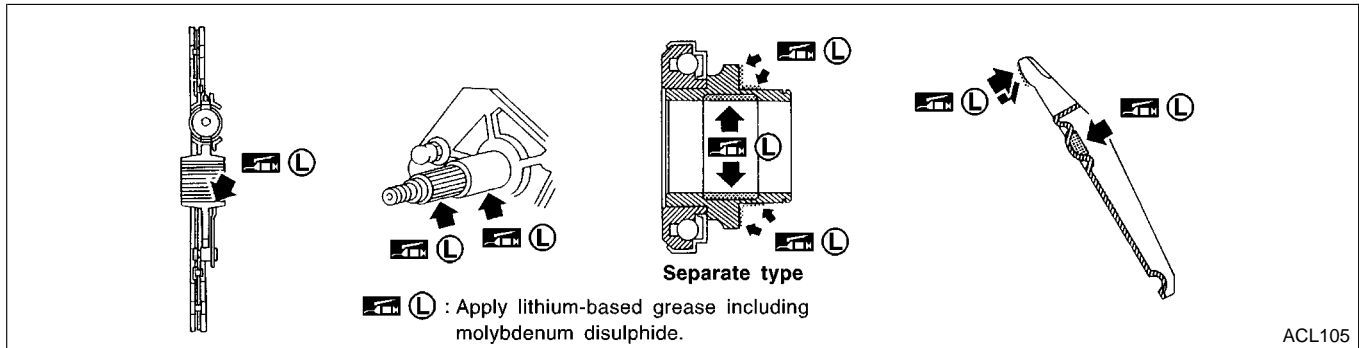

GI
MA
EM
LC
EC
FE

CL

MT

Lubrication

NGCL0016

- Apply recommended grease to contact surface and rubbing surface.
- **Too much lubricant might damage clutch disc facing damage.**

AT

TF

PD

AX

Waterproof — for 4WD Model

NGCL0017

- Apply recommended sealant to contact surface of dust cover to transmission case and withdrawal lever and then install dust cover clip.

Recommended sealant: Nissan genuine part (KP115-00100), Three Bond TB1212, Loctite Part Number 51813, or equivalent

SU

BR

ST

RS

BT

HA

SC

EL

IDX

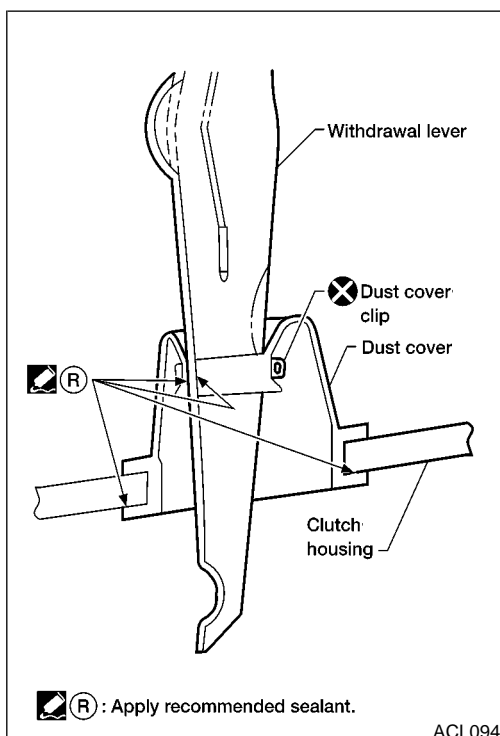

CLUTCH DISC, CLUTCH COVER AND FLYWHEEL

Components

Components

NGCL0018

SEC. 300

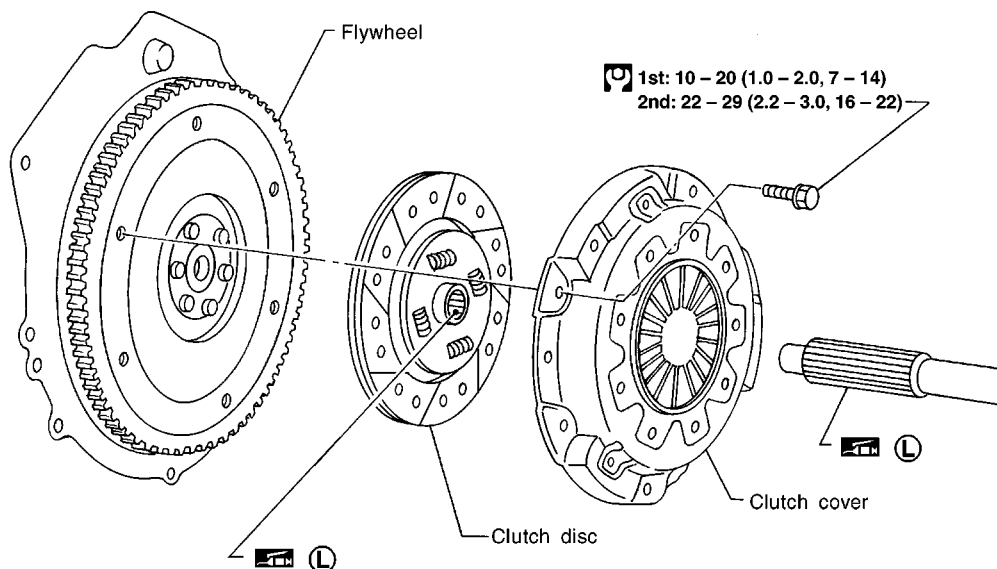

- Do not clean clutch disc surface with solvent.
 - When installing, be careful that grease from main drive shaft does not adhere to clutch disc.
- : Apply lithium-based grease including molybdenum disulphide.
 : N•m (kg-m, ft-lb)

ACL100

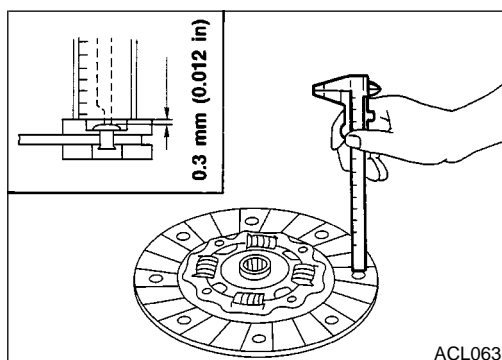

ACL063

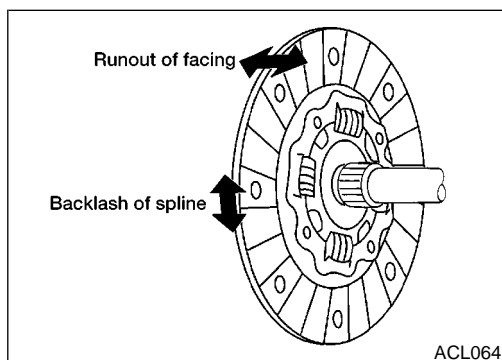

ACL064

Inspection and Adjustment

CLUTCH DISC

NGCL0019

NGCL0019S01

Check the following items, and replace if necessary.

- Clutch disc, for burns, discoloration, oil, or grease leakage
- Clutch disc, for wear of facing

Wear limit of facing surface to rivet head:
0.3 mm (0.012 in)

- Clutch disc, for backlash of spline and runout of facing
Maximum backlash of spline (at outer edge of disc):
1.0 mm (0.039 in)
Runout limit:
1.0 mm (0.039 in)
Distance of runout check point (from hub center):
Model 240: 115 mm (4.53 in)
Model 250: 120 mm (4.72 in)

CLUTCH DISC, CLUTCH COVER AND FLYWHEEL

Inspection and Adjustment (Cont'd)

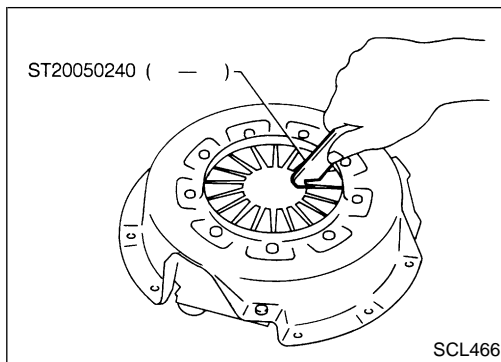

CLUTCH COVER AND FLYWHEEL

NGCL0019S02

- Check clutch cover, installed on vehicle, for uneven diaphragm spring toe height.

Uneven limit:

KA24DE: 0.7 mm (0.028 in)

VG33E: 0.5 mm (0.0020 in)

- If out of limit, adjust the height with Tool.

GI

MA

EM

LC

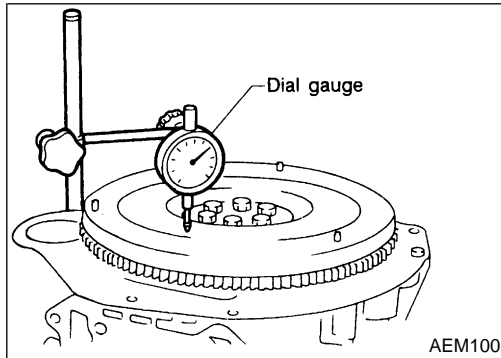

FLYWHEEL INSPECTION

NGCL0019S03

CAUTION:

Do not allow any magnetic materials to contact the ring gear teeth.

- Inspect contact surface of flywheel for slight burns or discoloration. Clean flywheel with emery paper.

- Check flywheel runout.

Maximum allowable runout:

Refer to *EM-52* (KA24DE engine) or *EM-110* (VG33E engine), "Inspection", "CYLINDER BLOCK".

EC

FE

CL

MT

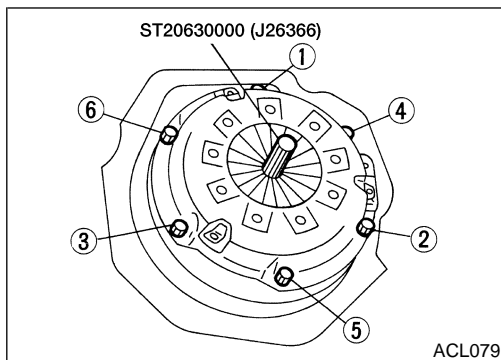

Installation

NGCL0020

- Apply recommended grease to contact surface of splines.
- **Too much lubricant may damage clutch disc facing.**
- Insert Tool into clutch disc hub when installing clutch cover and disc.
- Be careful not to allow grease to contaminate clutch facing.
- Tighten bolts in numerical order, in two steps.

First step:

 : 10 - 20 N·m (1.0 - 2.0 kg·m, 7 - 14 ft·lb)

Final step:

 : 22 - 29 N·m (2.2 - 3.0 kg·m, 16 - 22 ft·lb)

AT

TF

PD

AX

SU

BR

ST

RS

BT

HA

SC

EL

IDX

SERVICE DATA AND SPECIFICATIONS (SDS)

Clutch Control System

Clutch Control System		NGCL0028
Type of clutch control	Hydraulic	

Clutch Master Cylinder (with clutch damper)

Clutch Master Cylinder (with clutch damper)		NGCL0021
Inner diameter	15.87 mm (5/8 in)	

Clutch Operating Cylinder

Clutch Operating Cylinder		NGCL0022
Inner diameter	19.05 mm (3/4 in)	

Clutch Disc

Clutch Disc		NGCL0023 Unit: mm (in)
Model	250	
Engine	VG33E	
Facing size (Outer dia. x inner dia. x thickness)	250 x 160 x 3.5 (9.84 x 6.30 x 0.138)	
Thickness of disc assembly with load	8.1 - 8.5 (0.3189 - 0.3346) with 6,473 N (660 kg, 1,455 lb)	
Wear limit of facing surface to rivet head	0.3 (0.012)	
Runout limit of facing	1.0 (0.039)	
Distance of runout check point (from hub center)	120 (4.72)	
Maximum backlash of spline (at outer edge of disc)	1.0 (0.039)	

Clutch Cover

Clutch Cover		NGCL0024 Unit: mm (in)
Engine	VG33E	
Model	250	
Set-load	2WD	4,658 N (475 kg, 1,047 lb)
	4WD	4,658 N (475 kg, 1,047 lb)
Diaphragm spring height	36.5 - 38.5 (1.437 - 1.516)	
Uneven limit of diaphragm spring toe height	0.5 (0.020)	

Clutch Pedal

Clutch Pedal		NGCL0025 Unit: mm (in)
Engine	VG33E	
Pedal height "H"*	227 - 237 (8.94 - 9.33)	
Pedal free play "A" (at pedal pad)	7 - 14 (0.27 - 0.55)	
Clearance "C" between pedal stopper bracket and clutch pedal position switch (with clutch pedal fully depressed.)	0.1 - 1.0 (0.004 - 0.039)	

*: Measured from surface of dash lower panel to pedal pad.