

CLUTCH

SECTION **CL**

CONTENTS

PRECAUTIONS	2	CLUTCH RELEASE MECHANISM	10
Precautions	2	Components.....	10
PREPARATION	3	Removal and Installation	10
Special Service Tools	3	Inspection.....	11
Commercial Service Tools	3	Lubrication	11
NOISE, VIBRATION AND HARSHNESS (NVH)		CLUTCH DISC, CLUTCH COVER AND	
TROUBLESHOOTING	4	FLYWHEEL	12
NVH Troubleshooting Chart.....	4	Components.....	12
CLUTCH	4	Inspection and Adjustment	12
CLUTCH SYSTEM - HYDRAULIC TYPE	5	CLUTCH DISC.....	12
Components.....	5	CLUTCH COVER AND FLYWHEEL.....	13
Inspection and Adjustment	6	FLYWHEEL INSPECTION	13
CLUTCH PEDAL INSPECTION AND		Installation.....	13
ADJUSTMENT	6	SERVICE DATA AND SPECIFICATIONS (SDS)	15
AIR BLEEDING PROCEDURE	7	Clutch Control System.....	15
CLUTCH MASTER CYLINDER	8	Clutch Master Cylinder (with clutch damper)	15
Components.....	8	Clutch Operating Cylinder	15
Disassembly and Assembly.....	8	Clutch Disc.....	15
Inspection.....	8	Clutch Cover	15
OPERATING CYLINDER	9	Clutch Pedal	15
Components.....	9		
Inspection.....	9		

GI

MA

EM

LC

EC

FE

CL

MT

AT

TF

PD

AX

SU

BR

ST

RS

BT

HA

SC

EL

IDX

PRECAUTIONS

Precautions

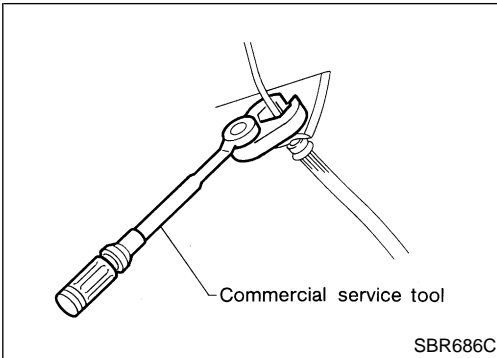

Precautions

NGCL0001

- Recommended fluid is brake fluid "DOT 3".
- Never reuse drained brake fluid.
- Be careful not to splash brake fluid on painted areas.
- When removing and installing clutch piping, use Tool.
- Use new brake fluid to clean or wash all parts of master cylinder, operating cylinder, and clutch damper.
- Never use mineral oils such as gasoline or kerosene. It will ruin the rubber parts of the hydraulic system.

WARNING:

After cleaning the clutch disc, wipe it with a dust collector. Do not use compressed air.

PREPARATION

Special Service Tools

Special Service Tools

NGCL0002

The actual shapes of Kent-Moore tools may differ from those of special service tools illustrated here.

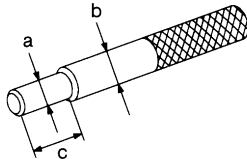
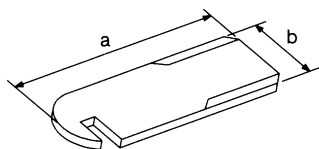
Tool number (Kent-Moore No.) Tool name	Description	
ST20630000 (J26366) Clutch aligning bar	 <p>NT405</p>	Installing clutch cover and clutch disc a: 15.9 mm (0.626 in) dia. b: 22.8 mm (0.898 in) dia. c: 55 mm (2.17 in)
ST20050240 (—) Diaphragm spring adjusting wrench	 <p>NT404</p>	Adjusting unevenness of diaphragm spring of clutch cover a: 150 mm (5.91 in) b: 25 mm (0.98 in)

Commercial Service Tools

NGCL0003

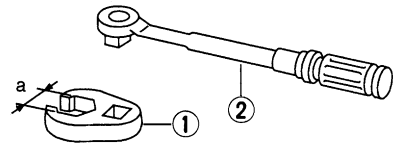
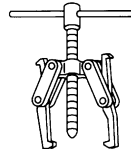
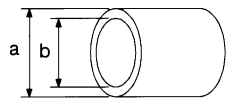
Tool name	Description	
1 Flare nut crowfoot 2 Torque wrench	 <p>NT360</p>	Removing and installing clutch piping a: 10 mm (0.39 in)
Bearing puller	 <p>NT077</p>	Removing release bearing
Bearing drift	 <p>NT474</p>	Installing release bearing a: 52 mm (2.05 in) dia. b: 45 mm (1.77 in) dia.

GI

MA

EM

LC

EC

FE

CL

MT

AT

TF

PD

AX

SU

BR

ST

RS

BT

HA

SC

EL

IDX

NOISE, VIBRATION AND HARSHNESS (NVH) TROUBLESHOOTING

NVH Troubleshooting Chart

NVH Troubleshooting Chart

NGCL0027S01

Use the chart below to help you find the cause of the problem. The numbers indicate the priority of the likely cause of the problem. Check each part in order. If necessary, repair or replace these parts.

CLUTCH

NGCL0027S0101

Reference page		CL-6	CL-7	CL-8	CL-9	EM-41 (KA24DE), EM-113 (VG33E & VG33ER)	CL-10	CL-12	CL-12	CL-12	CL-12	CL-12	CL-12	CL-12	CL-12	CL-12	CL-12	CL-12	CL-12	CL-12	CL-13	CL-13	CL-13	CL-13
SUSPECTED PARTS (Possible cause)		CLUTCH PEDAL (Free play out of adjustment)	CLUTCH LINE (Air in line)	MASTER CYLINDER PISTON CUP (Damaged)	OPERATING CYLINDER PISTON CUP (Damaged)	ENGINE MOUNTING (Loose)	RELEASE BEARING (Worn, dirty or damaged)	CLUTCH DISC (Out of true)	CLUTCH DISC (Runout is excessive)	CLUTCH DISC (Lining broken)	CLUTCH DISC (Dirty or burned)	CLUTCH DISC (Oily)	CLUTCH DISC (Worn out)	CLUTCH DISC (Hardened)	CLUTCH DISC (Lack of spline grease)	DIAPHRAGM SPRING (Damaged)	DIAPHRAGM SPRING (Out of tip alignment)	PRESSURE PLATE (Distortion)	FLYWHEEL (Distortion)					
Symptom	Clutch grabs/chatters					1			2				2	2	2									
	Clutch pedal spongy		1	2	2																			
	Clutch noisy						1																	
	Clutch slips	1											2	2							3		4	5
	Clutch does not disengage	1	2	3	4				5	5	5	5	5		5	6	6	6	7					

CLUTCH SYSTEM — HYDRAULIC TYPE

Components

Components

NGCL0004

SEC. 300 • 305 • 306 • 465

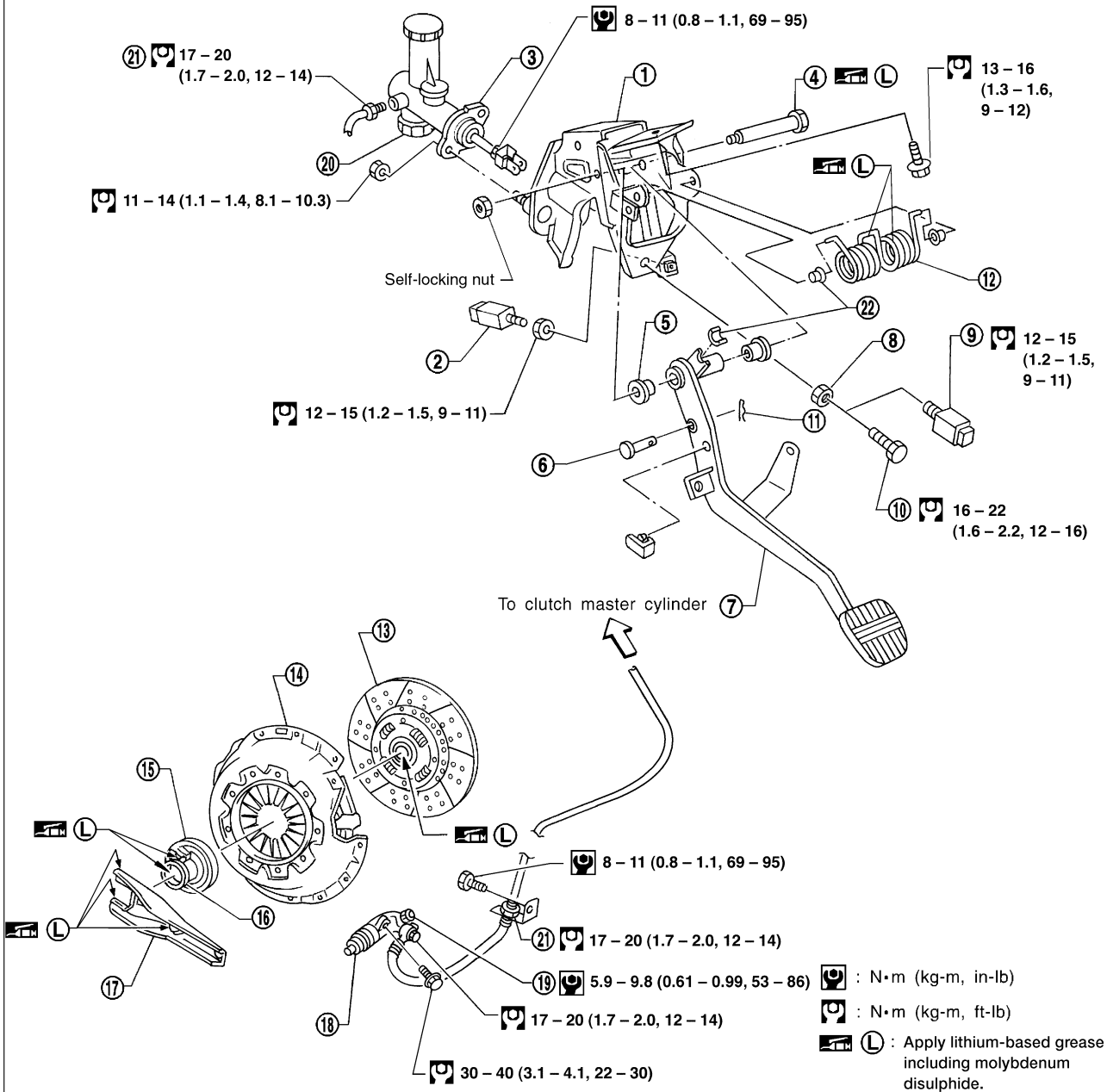

WCL044

- | | | |
|----------------------------|-----------------------|----------------------------|
| 1. Clutch pedal bracket | 9. ASCD cancel switch | 16. Release bearing sleeve |
| 2. Clutch interlock switch | 10. Pedal stopper | 17. Withdrawal lever |
| 3. Clutch master cylinder | 11. Snap pin | 18. Operating cylinder |
| 4. Fulcrum pin | 12. Assist spring | 19. Air bleeder |
| 5. Bushing | 13. Clutch disc | 20. Clutch damper |
| 6. Clevis pin | 14. Clutch cover | 21. Flare nut |
| 7. Clutch pedal | 15. Release bearing | 22. Bushing |
| 8. Lock nut | | |

GI
MA
EM
LC
EC
FE
CL
MT
AT
TF
PD
AX
SU
BR
ST
RS
BT
HA
SC
EL
IDX

CLUTCH SYSTEM — HYDRAULIC TYPE

Inspection and Adjustment

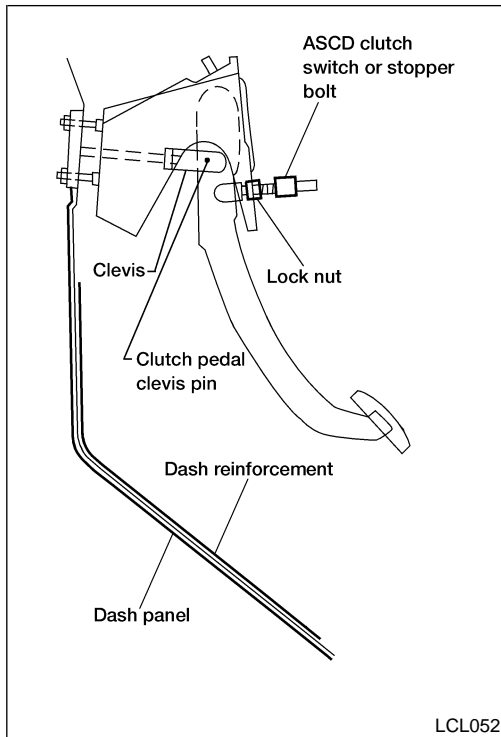

Inspection and Adjustment

CLUTCH PEDAL INSPECTION AND ADJUSTMENT

NGCL0005

NGCL0005S01

1. Check to see if the clutch pedal clevis pin floats freely in the bore of the clutch pedal. It should not be bound by the clevis or clutch pedal.
 - a. If the pin is not free, check that the ASCD switch or pedal stopper bolt is not applying pressure to the clutch pedal causing the pin to bind. To adjust, loosen the ASCD switch or pedal stopper bolt lock nut and turn the ASCD switch or pedal stopper bolt.
 - b. Tighten the lock nut.
 - c. Verify that the clutch pedal clevis pin floats freely in the bore of the clutch pedal. It should not be bound by the clevis or clutch pedal.
 - d. If the pin is still not free, remove the pin and check for deformation or damage. Replace the pin if necessary. Leave the pin removed for step 2.
2. Check the clutch pedal stroke for free range of movement.
 - a. With the clutch pedal clevis pin removed, manually move the pedal up and down to determine if it moves freely.
 - b. If any sticking is noted, replace the related parts (clutch pedal, pedal bracket, assist spring, bushing, etc.). Reassemble the pedal and re-verify that the clevis pin floats freely in the bore of the pedal.

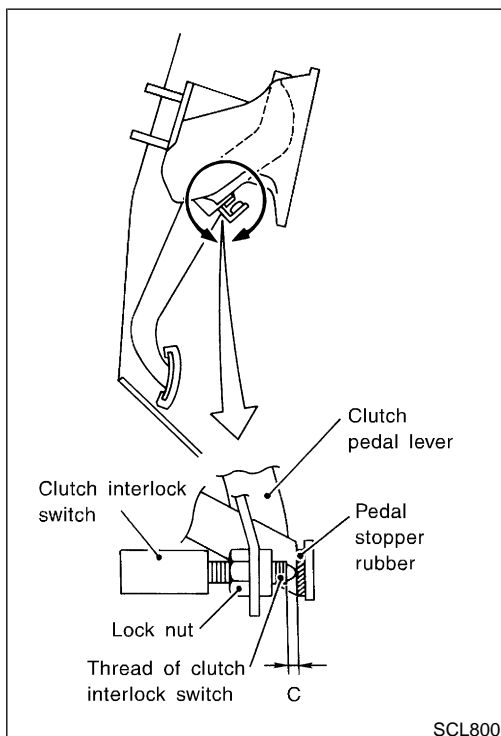

3. Adjust the clearance "C" while fully depressing the clutch pedal (with the clutch interlock switch) as shown.

Clearance "C": 0.1 - 1.0 mm (0.004 - 0.039 in)
4. Check the clutch hydraulic system components (clutch master cylinder, clutch operating cylinder, clutch withdrawal lever, clutch release bearing, etc.) for sticking or binding.
 - a. If any sticking or binding is noted, repair or replace the related parts as necessary.
 - b. If the hydraulic system was necessary, bleed the clutch hydraulic system. Refer to "Air Bleeding Procedure", CL-7.

CLUTCH SYSTEM — HYDRAULIC TYPE

Inspection and Adjustment (Cont'd)

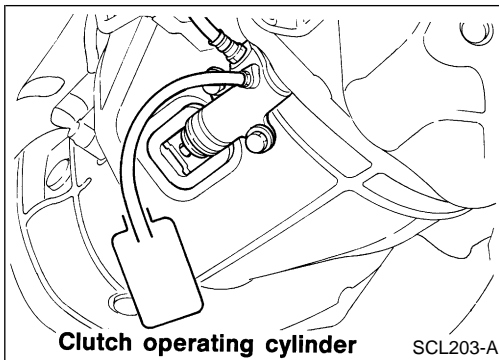

AIR BLEEDING PROCEDURE

NGCL0005S02

Bleed air according to the following procedure.

Bleed air from operating cylinder.

1. Fill the master cylinder reservoir tank with new brake fluid.
2. Connect a transparent vinyl hose to the air bleeder.
3. Slowly depress the clutch pedal to its full stroke length and release it completely. Repeat this operation several times at 2 to 3 second intervals.
4. Open the air bleeder with the clutch pedal fully depressed.
5. Close the air bleeder.
6. Release the clutch pedal and wait at least 5 seconds.
7. Repeat steps 3 through 6 above until air bubbles no longer appear in the brake fluid.

GI

MA

EM

LC

EC

FE

CL

MT

AT

TF

PD

AX

SU

BR

ST

RS

BT

HA

SC

EL

IDX

CLUTCH MASTER CYLINDER

Components

Components

NGCL0006

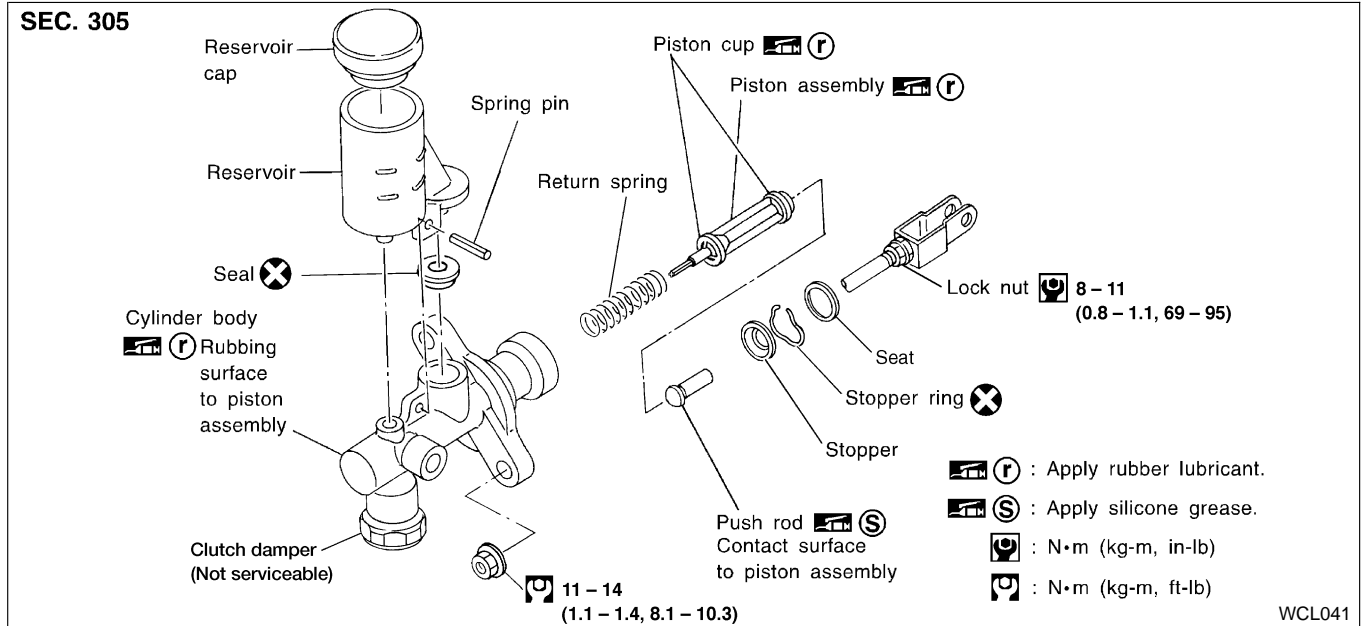

Disassembly and Assembly

NGCL0007

- Use a screwdriver to remove stopper ring while pushing push rod into cylinder.
- When installing stopper ring, tap in lightly while pushing push rod into cylinder.

Inspection

NGCL0008

Check the following items, and replace if necessary.

- Rubbing surface of cylinder and piston, for uneven wear, rust, or damage
- Piston with piston cup, for wear or damage
- Return spring, for wear or damage
- Reservoir, for deformation or damage

Components

NGCL0009

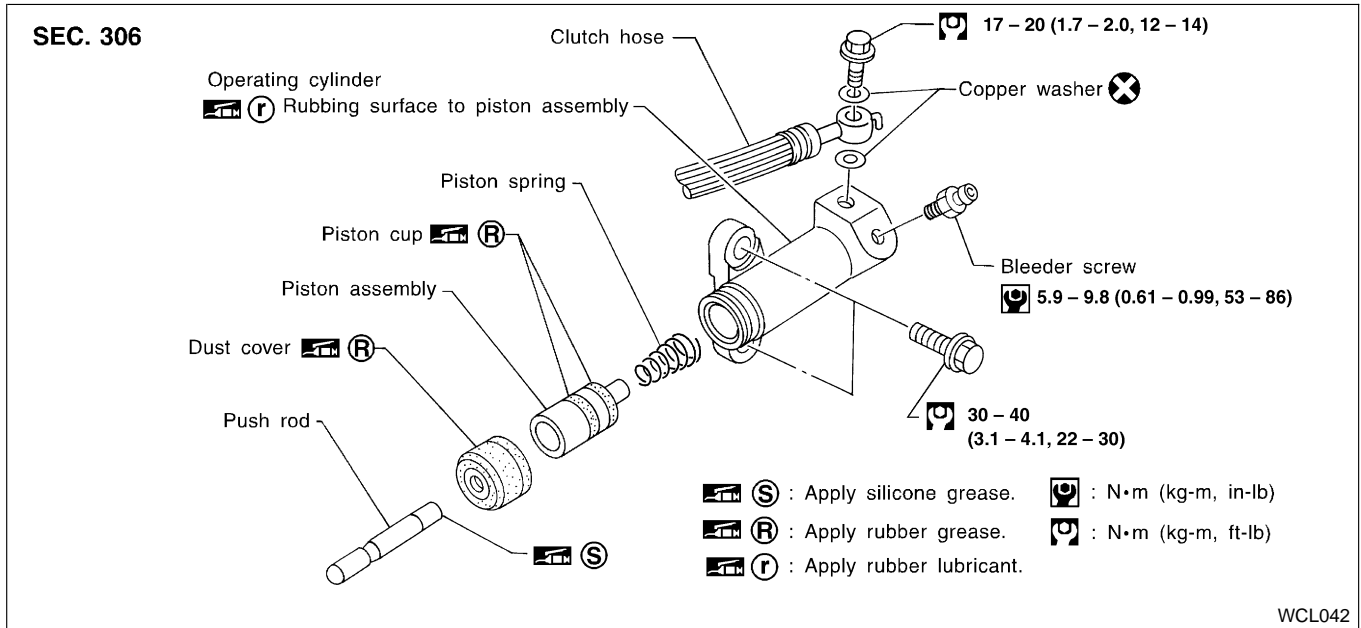

GI

MA

EM

LC

EC

FE

CL

MT

Inspection

NGCL0010

Check the following items, and replace if necessary.

- Rubbing surface of cylinder and piston, for uneven wear, rust, or damage
- Piston with piston cup, for wear or damage
- Piston spring, for wear or damage
- Dust cover, for cracks, deformation, or damage

AT

TF

PD

AX

SU

BR

ST

RS

BT

HA

SC

EL

IDX

CLUTCH RELEASE MECHANISM

Components

Components

NGCL0013

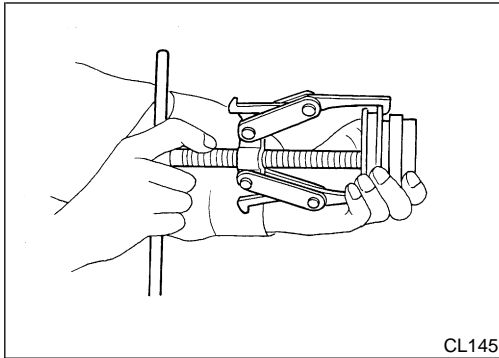
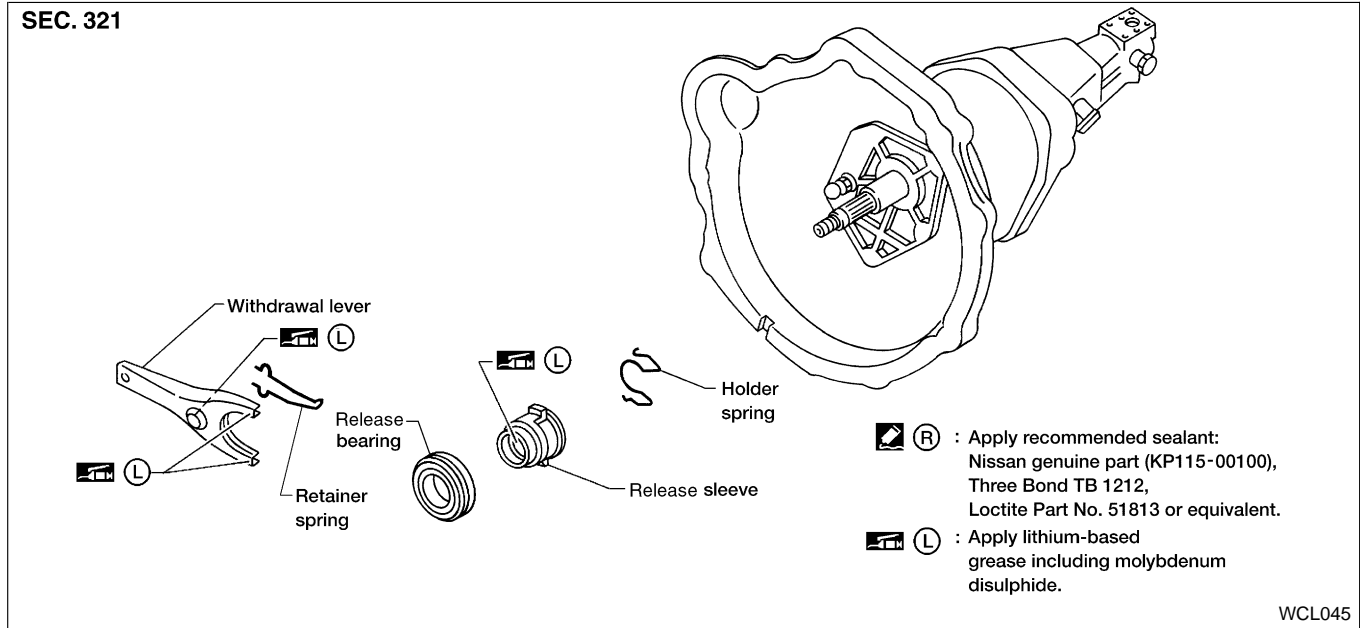

Removal and Installation

NGCL0014

- Remove release bearing.
- Install release bearing with suitable drift.
- Install retainer spring and holder spring.

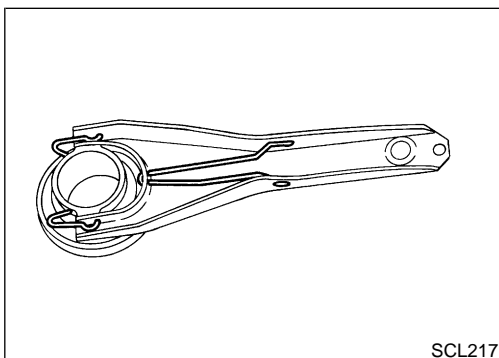
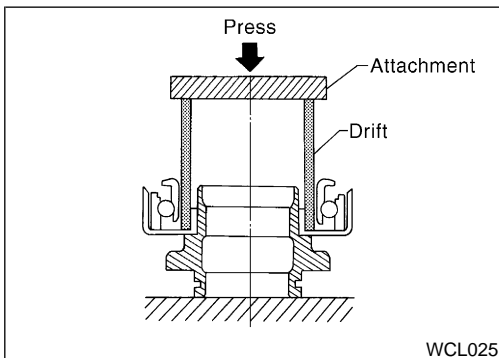

CLUTCH RELEASE MECHANISM

Inspection

Inspection

NGCL0015

Check the following items, and replace if necessary.

- Release bearing, to see that it rolls freely and is free from noise, cracks, pitting, or wear.
- Release sleeve and withdrawal lever rubbing surface, for wear, rust, or damage

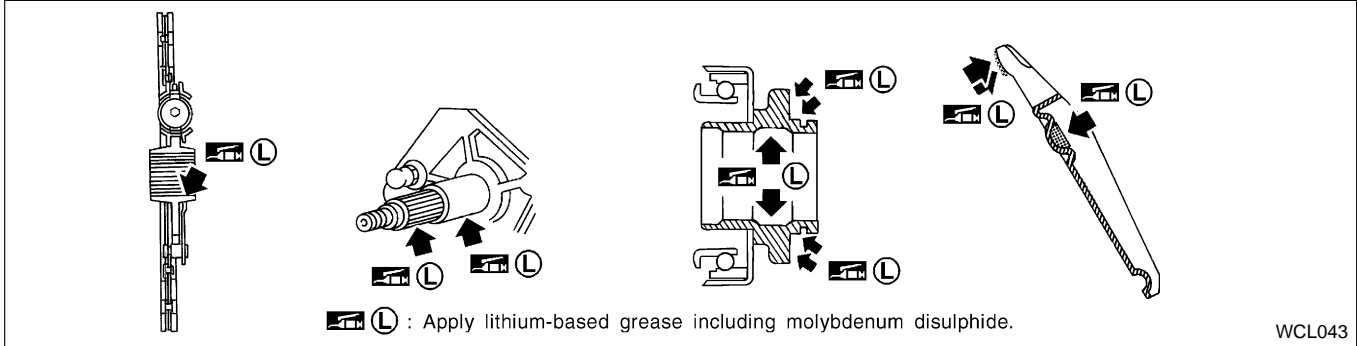

GI

MA

EM

LC

EC

FE

CL

MT

Lubrication

NGCL0016

- Apply recommended grease to contact surface and rubbing surface.
- **Too much lubricant might damage clutch disc facing damage.**

AT

TF

PD

AX

SU

BR

ST

RS

BT

HA

SC

EL

IDX

CLUTCH DISC, CLUTCH COVER AND FLYWHEEL

Components

Components

NGCL0018

SEC. 300

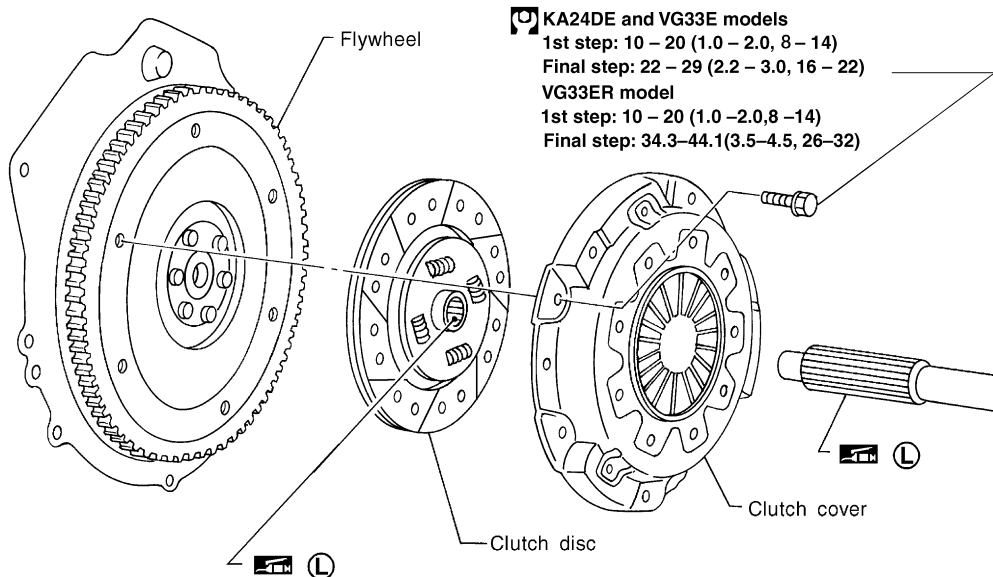

- Do not clean clutch disc surface with solvent.
 - When installing, be careful that grease from main drive shaft does not adhere to clutch disc.
- Apply lithium-based grease including molybdenum disulphide.
- N•m (kg-m, ft-lb)

WCL034

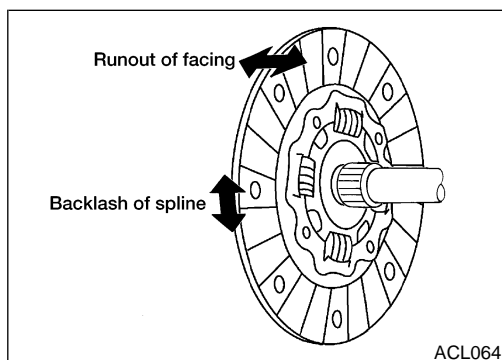
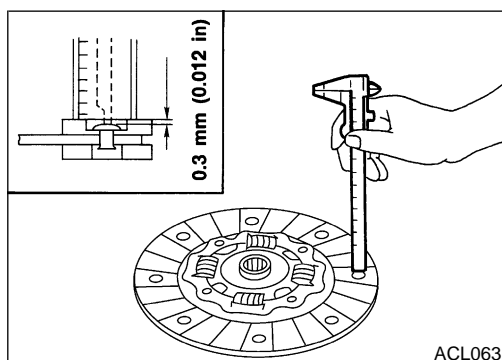

Inspection and Adjustment

CLUTCH DISC

NGCL0019

NGCL0019S01

Check the following items, and replace if necessary.

- Clutch disc, for burns, discoloration, oil, or grease leakage
- Clutch disc, for wear of facing

Wear limit of facing surface to rivet head:
0.3 mm (0.012 in)

- Clutch disc, for backlash of spline and runout of facing
 - Maximum backlash of spline (at outer edge of disc):**
1.0 mm (0.039 in)
 - Runout of facing limit (at outer edge of disc):**
1.0 mm (0.039 in)
 - Distance of runout check point (from hub center):**
Model 240: 115 mm (4.53 in)
Model 250: 120 mm (4.72 in)

CLUTCH DISC, CLUTCH COVER AND FLYWHEEL

Inspection and Adjustment (Cont'd)

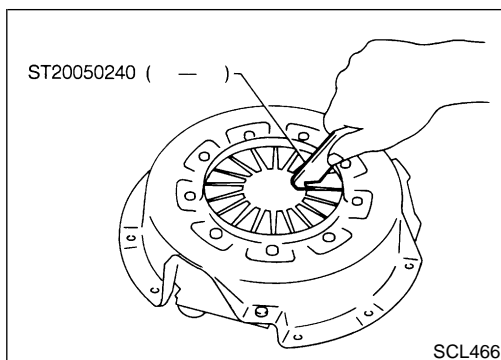

CLUTCH COVER AND FLYWHEEL

NGCL0019S02

- Check clutch cover, installed on vehicle, for uneven diaphragm spring toe height.
Uneven limit: 0.7 mm (0.028 in)
- If out of limit, adjust the height with Tool.

GI

MA

EM

LC

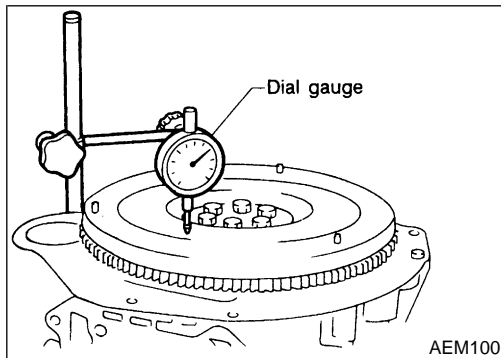

FLYWHEEL INSPECTION

NGCL0019S03

CAUTION:

Do not allow any magnetic materials to contact the ring gear teeth.

- Inspect contact surface of flywheel for slight burns or discoloration. Clean flywheel with emery paper.
- Check flywheel runout. Refer to **EM-52** (KA24DE), or **EM-124** (VG33E, VG33ER), "FLYWHEEL/DRIVE PLATE RUNOUT".

EC

FE

CL

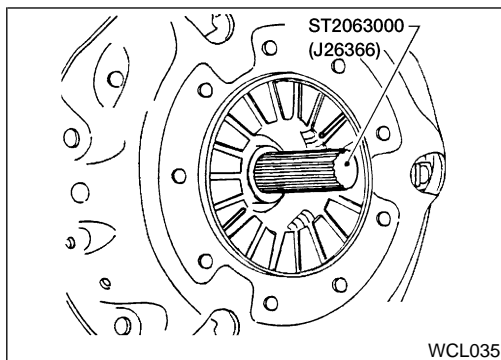

Installation

NGCL0020

- Apply recommended grease to contact surface of splines.
- **Too much lubricant may damage clutch disc facing.**
- Insert Tool into clutch disc hub when installing clutch cover and disc.
- Be careful not to allow grease to contaminate clutch facing.

AT

TF

PD

AX

SU

BR

ST

RS

BT

HA

SC

EL

IDX

CLUTCH DISC, CLUTCH COVER AND FLYWHEEL

Installation (Cont'd)

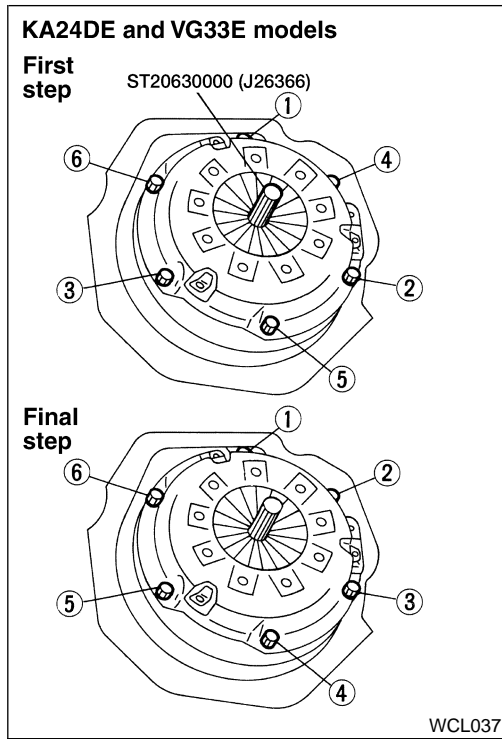

- Tighten bolts in numerical order, in two steps.

KA24DE, VG33E models

First step:

: 10 - 20 N·m (1.0 - 2.0 kg·m, 8 - 14 ft·lb)

Final step:

: 22 - 29 N·m (2.2 - 3.0 kg·m, 16 - 22 ft·lb)

VG33ER model

First step:

: 10 - 20 N·m (1.0 - 2.0 kg·m, 8 - 14 ft·lb)

Final step:

: 34.3 - 44.1 N·m (3.5 - 4.5 kg·m, 26 - 32 ft·lb)

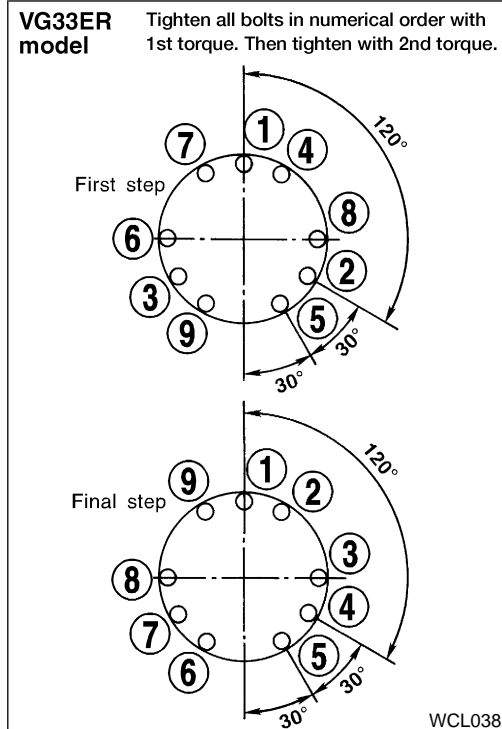

SERVICE DATA AND SPECIFICATIONS (SDS)

Clutch Control System

Clutch Control System

NGCL0028

Type of clutch control	Hydraulic
------------------------	-----------

Clutch Master Cylinder (with clutch damper)

NGCL0021

Inner diameter	15.87 mm (5/8 in)
----------------	-------------------

Clutch Operating Cylinder

NGCL0022

Inner diameter	19.05 mm (3/4 in)
----------------	-------------------

Clutch Disc

NGCL0023

Unit: mm (in)

Model	240	250	250
Engine	KA24DE	VG33E	VG33ER
Facing size (Outer dia. x inner dia. x thickness)	240 x 150 x 3.5 (9.45 x 5.91 x 0.138)	250 x 160 x 3.5 (9.84 x 6.30 x 0.138)	250 x 160 x 3.5 (9.84 x 6.30 x 0.138)
Thickness of disc assembly with load	7.75 - 8.25 (0.305 - 0.3248) with 4,903 N (500 kg, 1,103 lb)	8.1 - 8.5 (0.3189 - 0.3346) with 6,473 N (660 kg, 1,455 lb)	8.1 - 8.5 (0.3189 - 0.3346) with 4,903 N (500 kg, 1,103 lb)
Wear limit of facing surface to rivet head	0.3 (0.012)	0.3 (0.012)	0.3 (0.012)
Runout limit of facing	1.0 (0.039)	1.0 (0.039)	1.0 (0.039)
Distance of runout check point (from hub center)	115 (4.53)	120 (4.72)	120 (4.72)
Maximum backlash of spline (at outer edge of disc)	1.0 (0.039)	1.0 (0.039)	1.0 (0.039)

Clutch Cover

NGCL0024

Unit: mm (in)

Engine	KA24DE	VG33E	VG33ER	
Model	240	250	250	
Set-load	2WD	4,903 N (500 kg, 1,103 lb)	6,473 N (660 kg, 1,455 lb)	7,355 N (750 kg, 1,653 lb)
	4WD	—	6,473 N (660 kg, 1,455 lb)	7,355 N (750 kg, 1,653 lb)
Diaphragm spring height	37.5 - 39.5 (1.476 - 1.555)	36.5 - 38.5 (1.437 - 1.516)	37 - 39 (1.457 - 1.535)	
Uneven limit of diaphragm spring toe height	0.7 (0.028)	0.7 (0.028)	0.7 (0.028)	

Clutch Pedal

NGCL0025

Unit: mm (in)

Clearance "C" between pedal stopper bracket and clutch pedal position switch (with clutch pedal fully depressed.)	0.1 - 1.0 (0.004 - 0.039)
--	---------------------------

*: Measured from surface of dash lower panel to pedal pad.

GI

MA

EM

LC

EC

FE

CL

MT

AT

TF

PD

AX

SU

BR

ST

RS

BT

HA

SC

EL

IDX

NOTES