

A
B
C

SECTION SC

STARTING & CHARGING SYSTEM

CONTENTS

<p>PRECAUTIONS 2</p> <p style="padding-left: 20px;">Precautions for Supplemental Restraint System (SRS) "AIR BAG" and "SEAT BELT PRE-TENSIONER" 2</p> <p style="padding-left: 20px;">Precautions for Power Generation Variable Voltage Control System 2</p> <p style="padding-left: 20px;">Wiring Diagrams and Trouble Diagnosis 2</p> <p>PREPARATION 3</p> <p style="padding-left: 20px;">Special Service Tool 3</p> <p style="padding-left: 20px;">Commerical Service Tools 3</p> <p>BATTERY 4</p> <p style="padding-left: 20px;">How to Handle Battery 4</p> <p style="padding-left: 40px;">METHODS OF PREVENTING OVER-DISCHARGE 4</p> <p style="padding-left: 40px;">CHECKING ELECTROLYTE LEVEL 4</p> <p style="padding-left: 40px;">SPECIFIC GRAVITY CHECK 5</p> <p style="padding-left: 40px;">CHARGING THE BATTERY 6</p> <p style="padding-left: 20px;">Trouble Diagnoses with Battery/Starting/Charging System Tester 6</p> <p style="padding-left: 40px;">DIAGNOSTIC RESULT ITEM CHART 8</p> <p style="padding-left: 20px;">Removal and Installation 9</p> <p style="padding-left: 40px;">REMOVAL 9</p> <p style="padding-left: 40px;">INSTALLATION 9</p> <p>STARTING SYSTEM 10</p> <p style="padding-left: 20px;">System Description 10</p> <p style="padding-left: 40px;">A/T MODELS 10</p> <p style="padding-left: 40px;">M/T MODELS (USING IGNITION SWITCH) 10</p> <p style="padding-left: 40px;">M/T MODELS (USING CLUTCH INTERLOCK CANCEL SWITCH) 11</p> <p style="padding-left: 20px;">Wiring Diagram — START — 12</p> <p style="padding-left: 40px;">A/T MODELS 12</p> <p style="padding-left: 20px;">Schematic — M/T Models — 14</p> <p style="padding-left: 40px;">M/T MODELS 15</p> <p style="padding-left: 20px;">Trouble Diagnoses with Battery/Starting/Charging System Tester 18</p>	<p style="padding-left: 20px;">DIAGNOSTIC RESULT ITEM CHART 18</p> <p style="padding-left: 20px;">WORK FLOW 19</p> <p style="padding-left: 20px;">DIAGNOSTIC PROCEDURE 1 20</p> <p style="padding-left: 20px;">DIAGNOSTIC PROCEDURE 2 21</p> <p style="padding-left: 20px;">MINIMUM SPECIFICATION OF CRANKING VOLTAGE REFERENCING COOLANT TEMPERATURE 22</p> <p style="padding-left: 20px;">Removal and Installation 22</p> <p style="padding-left: 40px;">REMOVAL 22</p> <p style="padding-left: 40px;">INSTALLATION 23</p> <p>CHARGING SYSTEM 24</p> <p style="padding-left: 20px;">System Description 24</p> <p style="padding-left: 40px;">POWER GENERATION VARIABLE VOLTAGE CONTROL SYSTEM 24</p> <p style="padding-left: 20px;">Wiring Diagram — CHARGE — 26</p> <p style="padding-left: 20px;">Trouble Diagnoses with Battery/Starting/Charging System Tester 27</p> <p style="padding-left: 40px;">DIAGNOSTIC RESULT ITEM CHART 28</p> <p style="padding-left: 40px;">WORK FLOW 29</p> <p style="padding-left: 40px;">PRELIMINARY INSPECTION 30</p> <p style="padding-left: 40px;">DIAGNOSTIC PROCEDURE 1 30</p> <p style="padding-left: 40px;">DIAGNOSTIC PROCEDURE 2 31</p> <p style="padding-left: 40px;">DIAGNOSTIC PROCEDURE 3 31</p> <p style="padding-left: 40px;">DIAGNOSTIC PROCEDURE 4 32</p> <p style="padding-left: 20px;">Power Generation Variable Voltage Control System Inspection 33</p> <p style="padding-left: 20px;">Removal and Installation 34</p> <p style="padding-left: 40px;">REMOVAL 34</p> <p style="padding-left: 40px;">GENERATOR PULLEY INSPECTION 35</p> <p style="padding-left: 40px;">INSTALLATION 35</p> <p>SERVICE DATA AND SPECIFICATIONS (SDS) 36</p> <p style="padding-left: 20px;">Battery 36</p> <p style="padding-left: 20px;">Starter 36</p> <p style="padding-left: 20px;">Generator 36</p>
--	---

A
B
C
D
E
F
G
H
I
J
SC
L
M

PRECAUTIONS

PRECAUTIONS

PF0:00001

Precautions for Supplemental Restraint System (SRS) “AIR BAG” and “SEAT BELT PRE-TENSIONER”

EKS00D8I

The Supplemental Restraint System such as “AIR BAG” and “SEAT BELT PRE-TENSIONER”, used along with a front seat belt, helps to reduce the risk or severity of injury to the driver and front passenger for certain types of collision. This system includes seat belt switch inputs and dual stage front air bag modules. The SRS system uses the seat belt switches to determine the front air bag deployment, and may only deploy one front air bag, depending on the severity of a collision and whether the front occupants are belted or unbelted. Information necessary to service the system safely is included in the SRS and SB section of this Service Manual.

WARNING:

- To avoid rendering the SRS inoperative, which could increase the risk of personal injury or death in the event of a collision which would result in air bag inflation, all maintenance must be performed by an authorized NISSAN/INFINITI dealer.
- Improper maintenance, including incorrect removal and installation of the SRS, can lead to personal injury caused by unintentional activation of the system. For removal of Spiral Cable and Air Bag Module, see the SRS section.
- Do not use electrical test equipment on any circuit related to the SRS unless instructed to in this Service Manual. SRS wiring harnesses can be identified by yellow and/or orange harnesses or harness connectors.

Precautions for Power Generation Variable Voltage Control System

EKS00D8J

CAUTION:

For this model, the battery current sensor that is installed to the negative battery cable measures the charging/discharging current of the battery and performs various engine controls. If an electrical component is connected directly to the negative battery terminal, the current flowing through that component will not be measured by the battery current sensor. This condition may cause a malfunction of the engine control system and battery discharge may occur. Do not connect an electrical component or ground wire directly to the battery terminal.

Wiring Diagrams and Trouble Diagnosis

EKS00D8K

When you read wiring diagrams, refer to the following:

- [GI-15, "How to Read Wiring Diagrams"](#) .
- [PG-4, "POWER SUPPLY ROUTING CIRCUIT"](#) for power distribution circuit.

When you perform trouble diagnosis, refer to the following:

- [GI-11, "HOW TO FOLLOW TEST GROUPS IN TROUBLE DIAGNOSES"](#).
- [GI-27, "How to Perform Efficient Diagnosis for an Electrical Incident"](#).

PREPARATION

PREPARATION

PFP:00002

Special Service Tool

EKS00D8L

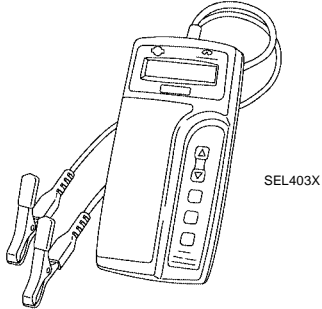
Tool number (Kent-Moore No.) Tool name	Description
J-44373 Model 620 Battery/Starting/Charging system tester	

Commerical Service Tools

EKS00D8M

Tool number Tool name	Description
Power tool	Loosening bolts and nuts

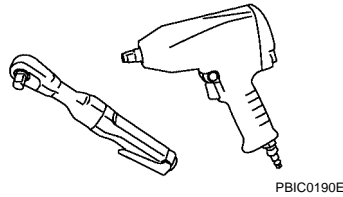

A
B
C
D
E
F
G
H
I
J

SC

L
M

BATTERY

PFP:AYBGL

BATTERY

How to Handle Battery

EKS00D8N

CAUTION:

- If it becomes necessary to start the engine with a booster battery and jumper cables, use a 12-volt booster battery.
- After connecting battery cables, ensure that they are tightly clamped to battery terminals for good contact.
- Never add distilled water through the hole used to check specific gravity.

METHODS OF PREVENTING OVER-DISCHARGE

The following precautions must be taken to prevent over-discharging a battery.

- The battery surface (particularly its top) should always be kept clean and dry.
- The terminal connections should be clean and tight.
- At every routine maintenance, check the electrolyte level. This also applies to batteries designated as "low maintenance" and "maintenance-free".

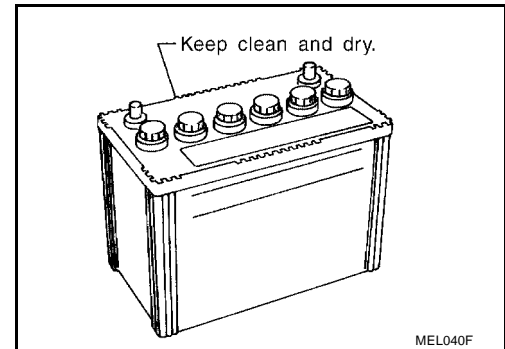

- When the vehicle is not going to be used over a long period of time, disconnect the negative battery terminal.

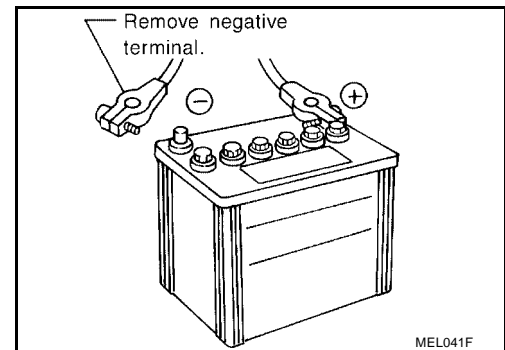

- Check the charge condition of the battery. Periodically check the specific gravity of the electrolyte. Keep a close check on charge condition to prevent over-discharge.

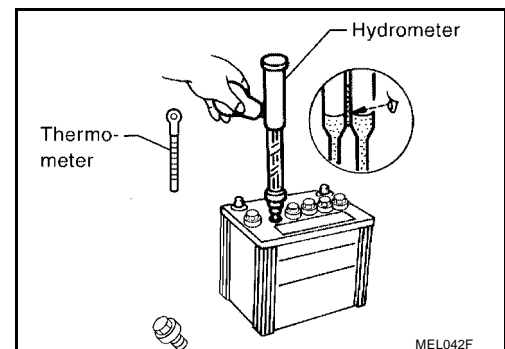

CHECKING ELECTROLYTE LEVEL

WARNING:

Do not allow battery fluid to come in contact with skin, eyes, fabrics, or painted surfaces. After touching a battery, do not touch or rub your eyes until you have thoroughly washed your hands. If acid contacts eyes, skin or clothing, immediately flush with water for 15 minutes and seek medical attention.

BATTERY

- Remove the cell plug using a suitable tool.
- Add distilled water up to the MAX level.

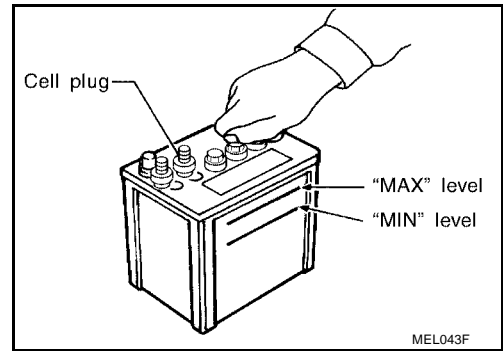

Sulphation

A battery will be completely discharged if it is left unattended for a long time and the specific gravity will become less than 1.100. This may result in sulphation on the cell plates.

To determine if a battery has been “sulphated”, note its voltage and current when charging it. As shown in the figure, less current and higher voltage are observed in the initial stage of charging sulphated batteries.

A sulphated battery may sometimes be brought back into service by means of a long, slow charge, 12 hours or more, followed by a battery capacity test.

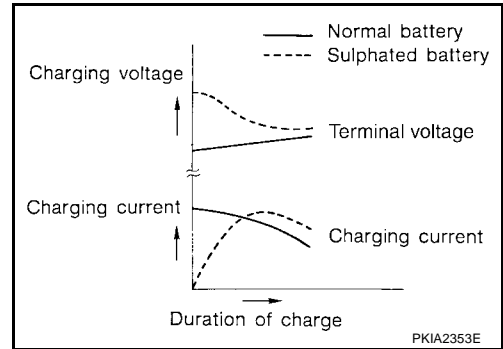

SPECIFIC GRAVITY CHECK

1. Read hydrometer and thermometer indications at eye level.
2. Use the following chart to correct your hydrometer reading according to electrolyte temperature.

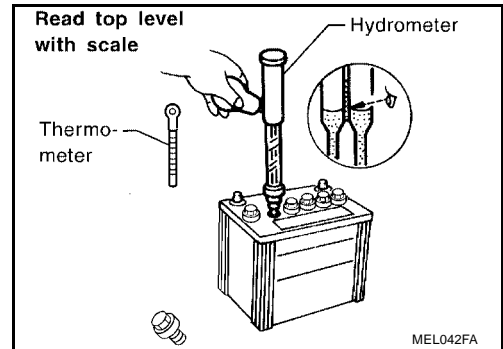

Hydrometer Temperature Correction

Battery electrolyte temperature °C (°F)	Add to specific gravity reading
71 (160)	0.032
66 (150)	0.028
60 (140)	0.024
54 (130)	0.020
49 (120)	0.016
43 (110)	0.012
38 (100)	0.008
32 (90)	0.004
27 (80)	0
21 (70)	-0.004
16 (60)	-0.008
10 (50)	-0.012
4 (40)	-0.016
-1 (30)	-0.020
-7 (20)	-0.024

A
B
C
D
E
F
G
H
I
J
SC

BATTERY

Battery electrolyte temperature °C (°F)	Add to specific gravity reading
-12 (10)	-0.028
-18 (0)	-0.032

Corrected specific gravity	Approximate charge condition
1.260 - 1.280	Fully charged
1.230 - 1.250	3/4 charged
1.200 - 1.220	1/2 charged
1.170 - 1.190	1/4 charged
1.140 - 1.160	Almost discharged
1.110 - 1.130	Completely discharged

CHARGING THE BATTERY

CAUTION:

- Do not “quick charge” a fully discharged battery.
- Keep the battery away from open flame while it is being charged.
- When connecting the charger, connect the leads first, then turn on the charger. Do not turn on the charger first, as this may cause a spark.
- If battery electrolyte temperature rises above 55°C (131°F), stop charging. Always charge battery at a temperature below 55°C (131°F).

Charging Rates

Amps	Time
50	1 hour
25	2 hours
10	5 hours
5	10 hours

Do not charge at more than 50 ampere rate.

NOTE:

The ammeter reading on your battery charger will automatically decrease as the battery charges. This indicates that the voltage of the battery is increasing normally as the state of charge improves. The charging amps indicated above refer to initial charge rate.

- If, after charging, the specific gravity of any two cells varies more than 0.050, the battery should be replaced.

Trouble Diagnoses with Battery/Starting/Charging System Tester

EKS00D80

CAUTION:

When working with batteries, always wear appropriate eye protection.

NOTE:

- To ensure a complete and thorough diagnosis, the battery, starter and generator test segments must be done as a set from start to finish.
- If battery surface charge is detected while testing, the tester will prompt you to turn on the headlights to remove the surface charge.
- If necessary, the tester will prompt you to determine if the battery temperature is above or below 0°C (32°F). Choose the appropriate selection by pressing the up or down arrow button, then press “ENTER” to make the selection.

BATTERY

1. Turn off all loads on the vehicle electrical system. Clean or repair as necessary.
2. Visually inspect the battery, battery terminals and cable ends with ignition switch in "OFF" position.

NOTE:

The contact surface between the battery terminals, cable ends and tester leads must be clean for a valid test. A poor connection will prevent testing and a "CHECK CONNECTION" message will appear during the test procedures. If this occurs, clean the battery post and terminals, reconnect them and restart the test.

3. Connect the red tester lead clamp to the positive battery terminal, and the black to the negative terminal.
4. The tester will turn on automatically. Using the arrow keys, select "IN-VEHICLE" on the tester and then press the "ENTER" key.

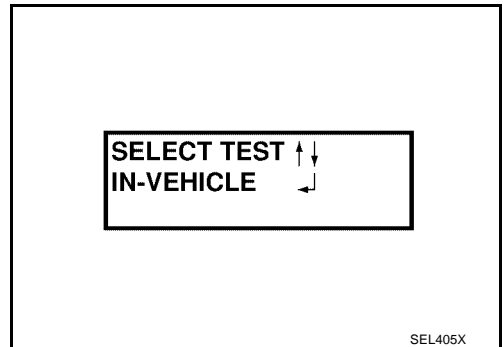
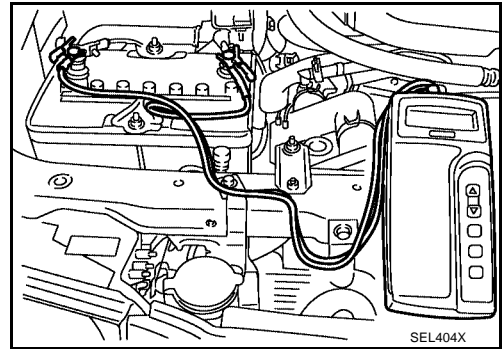

5. Locate the battery type and rating stamped or written on the top case of the battery to be tested.

NOTE:

The battery type and rating will have either of the following.

CCA: Cold Cranking Amps (490 CCA, 550 CCA, etc.)

JIS: Japanese Industrial Standard.

Battery is stamped with a number such as:

80D26L: 80 (rank of output), D (physical size-depth), 26 (width in cm). The last character L (post configuration) is not input into the tester.

The tester requires the rating for the battery be entered exactly as it is written or stamped on the battery. Do not attempt a CCA conversion for JIS stamped batteries. JIS must be input directly.

6. Using the arrow and "ENTER" keys alternately, select the battery type and rating.

NOTE:

The tester lists five choices; CCA, JIS, IEC, DIN, and EN. Only use CCA or JIS.

7. Press "ENTER" to begin the test. Diagnosis results are displayed on the tester. Refer to [SC-8. "DIAGNOSTIC RESULT ITEM CHART"](#).

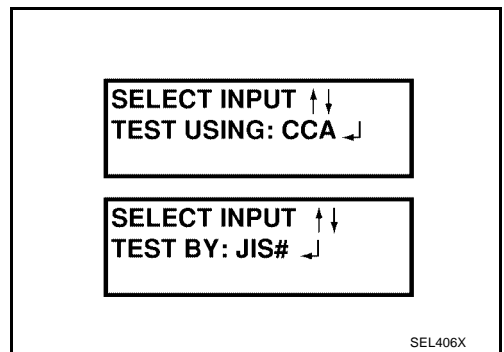

A
B
C
D
E
F
G
H
I
J
SC
L
M

BATTERY

8. Press "ENTER", then test output code is displayed. Record the test output code on the repair order.
9. Toggle back to the "DIAGNOSTIC SCREEN" for test results.

NOTE:

- If necessary, the tester will ask the user to determine if the battery has just been charged. Choose the appropriate selection by pressing the up or down arrow button and then press the "ENTER" button to make the selection.
- When testing a battery installed in a vehicle that has recently been driven, select "BEFORE CHARGE".
- If the battery has just been slow charged due to a "CHARGE & RETEST" decision by the tester, and the tester asks the user "BEFORE CHARGE/AFTER CHARGE", select "AFTER CHARGE".

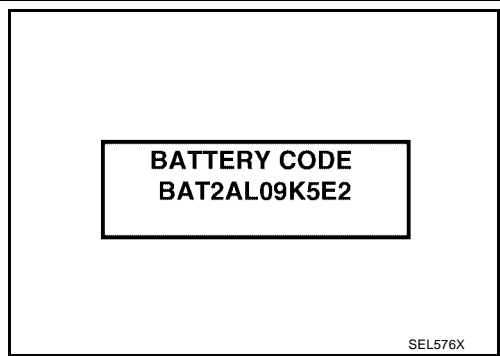

DIAGNOSTIC RESULT ITEM CHART

Diagnostic item	Service procedure
GOOD BATTERY	Battery is OK. Refer to SC-18. "Trouble Diagnoses with Battery/Starting/Charging System Tester" .
REPLACE BATTERY	Replace battery. Before replacing battery, clean the battery cable clamps and battery posts. Perform battery test again with Battery/Starting/Charging system tester. If second test result is "Replace Battery", then do so. Perform battery test again to confirm repair.
BAD CELL-REPLACE	Replace the battery. Perform battery test again with Battery/Starting/Charging system tester to confirm repair.
GOOD-RECHARGE	Perform the slow battery charging procedure. (Initial rate of charge is 10A for 12 hours.) Perform battery test again with Battery/Starting/Charging system tester.
CHARGE & RETEST	Perform the slow battery charging. (Initial rate of charge is 10A for 12 hours.) Perform battery test again with Battery/Starting/Charging system tester to confirm repair. NOTE: If the tester asks the user "BEFORE CHARGE/AFTER CHARGE", select "AFTER CHARGE".

BATTERY

Removal and Installation

EKS00D8P

REMOVAL

1. Disconnect both negative and positive battery terminal.

CAUTION:

When removing, remove negative battery terminal first.

2. Remove battery clamp bolts and battery clamp.
3. Remove battery.

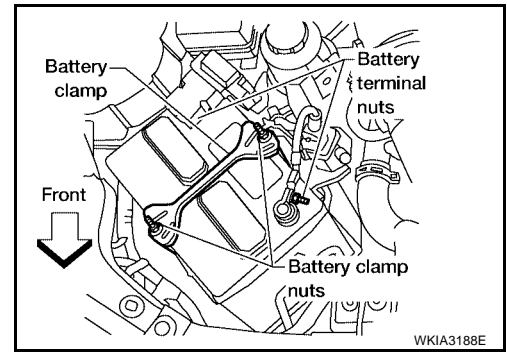

INSTALLATION

Installation is in the reverse order of removal.

Battery clamp nut : 3.4 N·m (0.35 kg-m, 30 in-lb)

Battery terminal nut : 3.4 N·m (0.35 kg-m, 30 in-lb)

CAUTION:

When installing, install positive battery terminal first.

A

B

C

D

E

F

G

H

I

J

SC

L

M

STARTING SYSTEM

PF23300

EKS00E24

STARTING SYSTEM

System Description A/T MODELS

Power is supplied at all times:

- to starter motor terminal 2, and
- through 40A fusible link (No. j , located in the fuse and fusible link box)
- to ignition switch terminal B.

With the ignition switch in the START position, power is supplied:

- from ignition switch terminal ST
- to IPDM E/R terminal 21.

With the ignition switch in the ON or START position, power is supplied to IPDM E/R (intelligent power distribution module engine room) CPU.

With the selector lever in the P or N position, power is supplied:

- through A/T assembly terminal 9
- to IPDM E/R terminal 48.

Ground is supplied at all times:

- to IPDM E/R terminals 38 and 59
- through body grounds E9, E15 and E24.

The IPDM E/R starter relay is energized and power is supplied:

- from terminal 19 of the IPDM E/R
- to terminal 1 of the starter motor.

The starter motor plunger closes and provides a closed circuit between the battery and the starter motor. The starter motor is grounded to the cylinder block. With power and ground supplied, the starter motor operates.

M/T MODELS (USING IGNITION SWITCH)

Power is supplied at all times:

- to starter motor terminal 2, and
- through 40A fusible link (No. j , located in the fuse and fusible link box)
- to ignition switch terminal B.

With the ignition switch in the START position, power is supplied:

- from ignition switch terminal ST
- to IPDM E/R terminal 21.

With the ignition switch in the ON or START position, power is supplied:

- to IPDM E/R (intelligent power distribution module engine room) CPU, and
- through 10A fuse (number 49, located in the IPDM E/R)
- to terminal 1 of the clutch interlock switch.

With the clutch pedal depressed, power is supplied:

- from clutch interlock switch terminal 2
- through diode - 3 (with clutch interlock cancel switch)
- to IPDM E/R terminal 48.

Ground is supplied at all times:

- to IPDM E/R terminals 38 and 59
- from body grounds E9, E15 and E24.

The IPDM E/R starter relay is energized and power is supplied:

- from terminal 19 of the IPDM E/R
- to terminal 1 of the starter motor.

The starter motor plunger closes and provides a closed circuit between the battery and the starter motor. The starter motor is grounded to the cylinder block. With power and ground supplied, the starter motor operates.

STARTING SYSTEM

M/T MODELS (USING CLUTCH INTERLOCK CANCEL SWITCH)

NOTE:

Vehicles with a manual transmission may be equipped with a clutch interlock cancel switch. This system description describes vehicle starting using the clutch interlock cancel switch. The use of the clutch interlock cancel switch allows the driver to start the vehicle without depressing the clutch pedal.

Power is supplied at all times:

- to starter motor terminal 2, and
- through 40A fusible link (No. j , located in the fuse and fusible link box)
- to ignition switch terminal B.

With the ignition switch in the START position, power is supplied:

- from ignition switch terminal ST
- to IPDM E/R terminal 21.

With the ignition switch in the ON or START position, power is supplied:

- to IPDM E/R (intelligent power distribution module engine room) CPU, and
- through 10A fuse (number 49, located in the IPDM E/R)
- to terminal 1 of the clutch interlock cancel switch, and
- to terminal 3 of the clutch interlock cancel relay 2.

With the clutch interlock cancel switch depressed, power is supplied:

- from clutch interlock cancel switch terminal 3
- through normally closed contacts (terminals 3 and 4) of clutch interlock cancel relay 1
- to terminal 2 of the clutch interlock cancel relay 2

Ground is supplied at all times:

- to IPDM E/R terminals 38 and 59, and
- to terminal 1 of clutch interlock cancel relay 2
- from body grounds E9, E15 and E24.

The clutch interlock cancel relay 2 is energized and power is supplied:

- from terminal 5 of the clutch interlock cancel relay 2
- to IPDM E/R terminal 48.

The IPDM E/R starter relay is energized and power is supplied:

- from terminal 19 of the IPDM E/R
- to terminal 1 of the starter motor.

The starter motor plunger closes and provides a closed circuit between the battery and the starter motor. The starter motor is grounded to the cylinder block. With power and ground supplied, the starter motor operates.

A
B
C
D
E
F
G
H
I
J
L
M

SC

STARTING SYSTEM

Wiring Diagram — START — A/T MODELS

EKS00EMF

SC-START-01

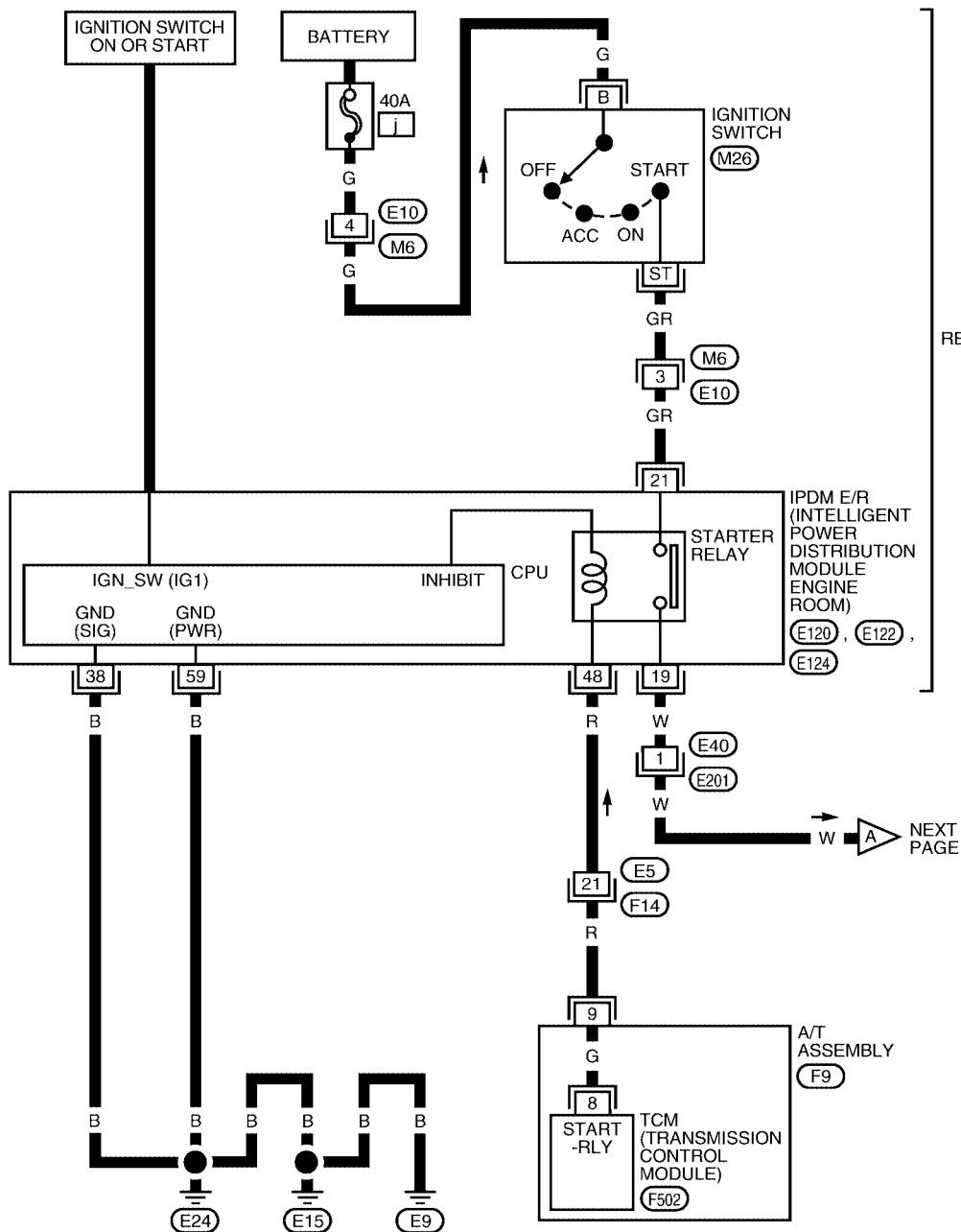

REFER TO "PG-POWER".

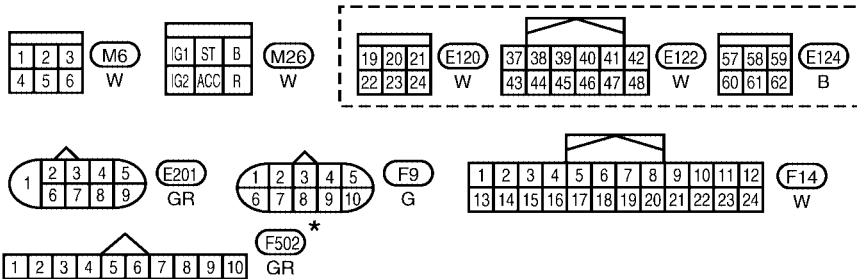

*: THIS CONNECTOR IS NOT SHOWN IN "HARNESS LAYOUT" OF PG SECTION.

WKWA2475E

STARTING SYSTEM

SC-START-02

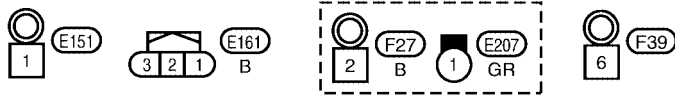
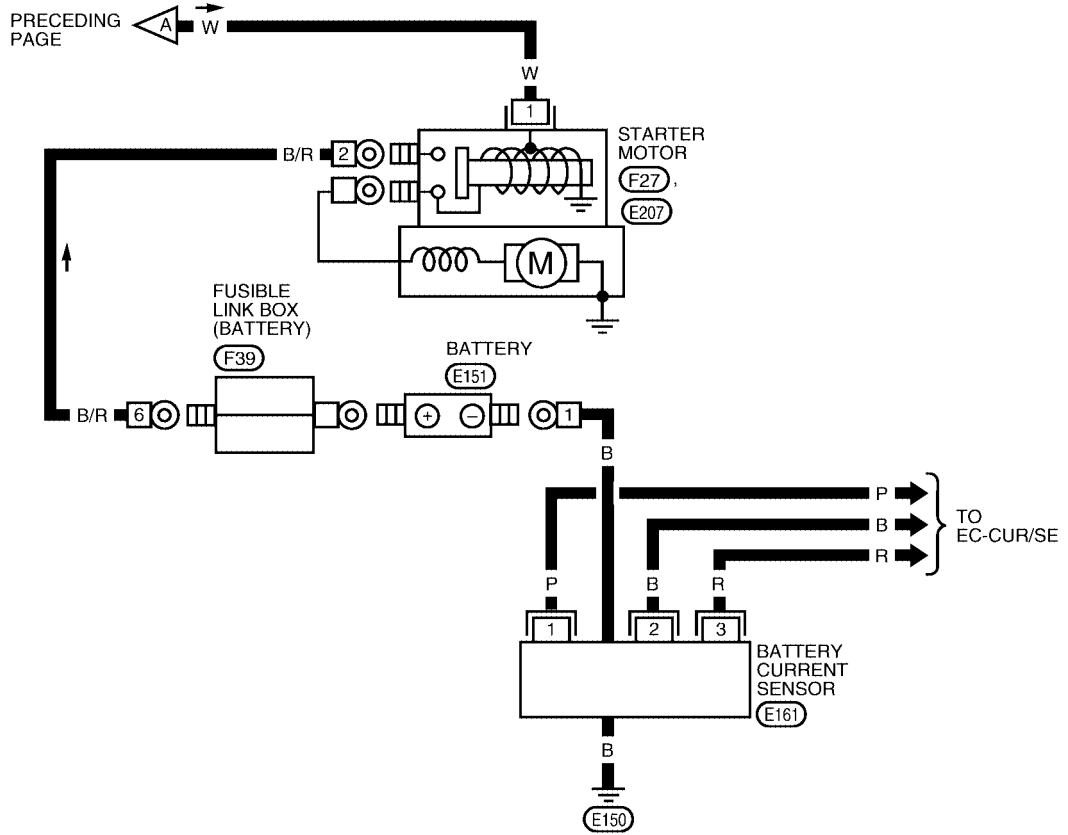

A
B
C
D
E
F
G
H
I
J
SC
L
M

STARTING SYSTEM

Schematic — M/T Models —

EKS00EMG

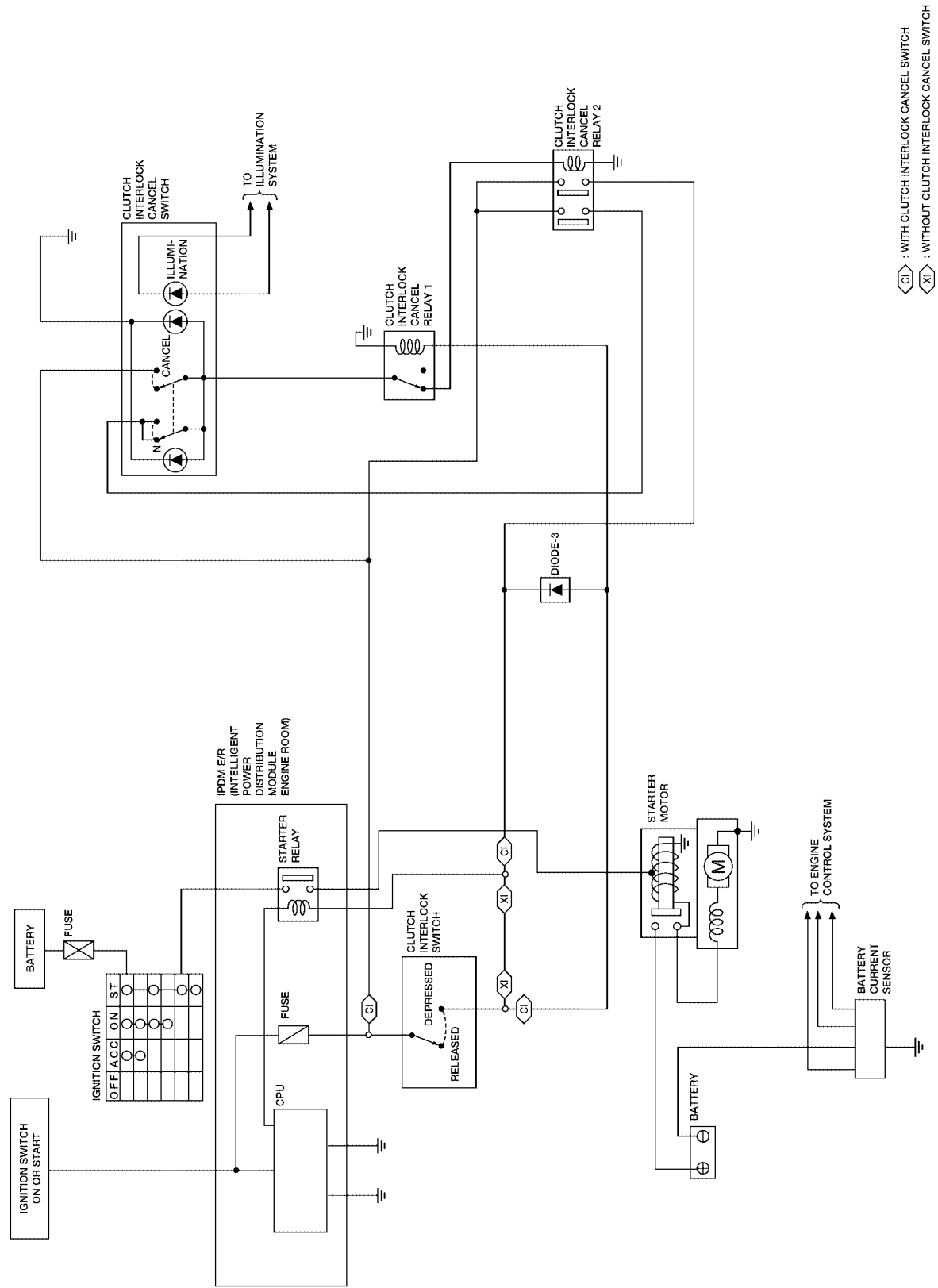

WKWA2481E

STARTING SYSTEM

SC-START-04

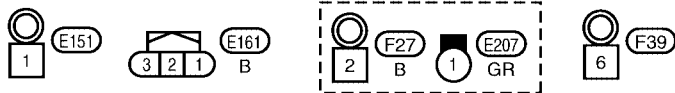
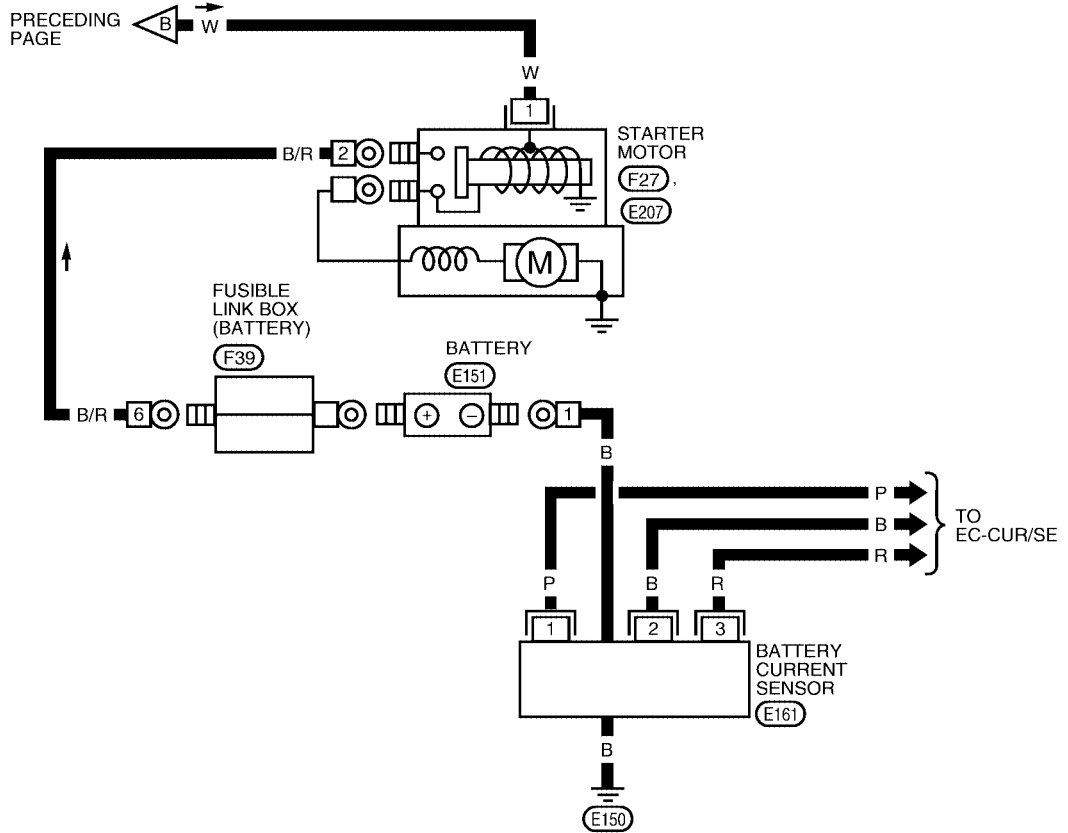

WKWA2478E

STARTING SYSTEM

SC-START-05

A
B
C
D
E
F
G
H
I
J
SC
L
M

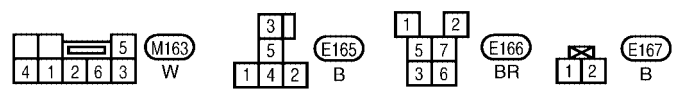
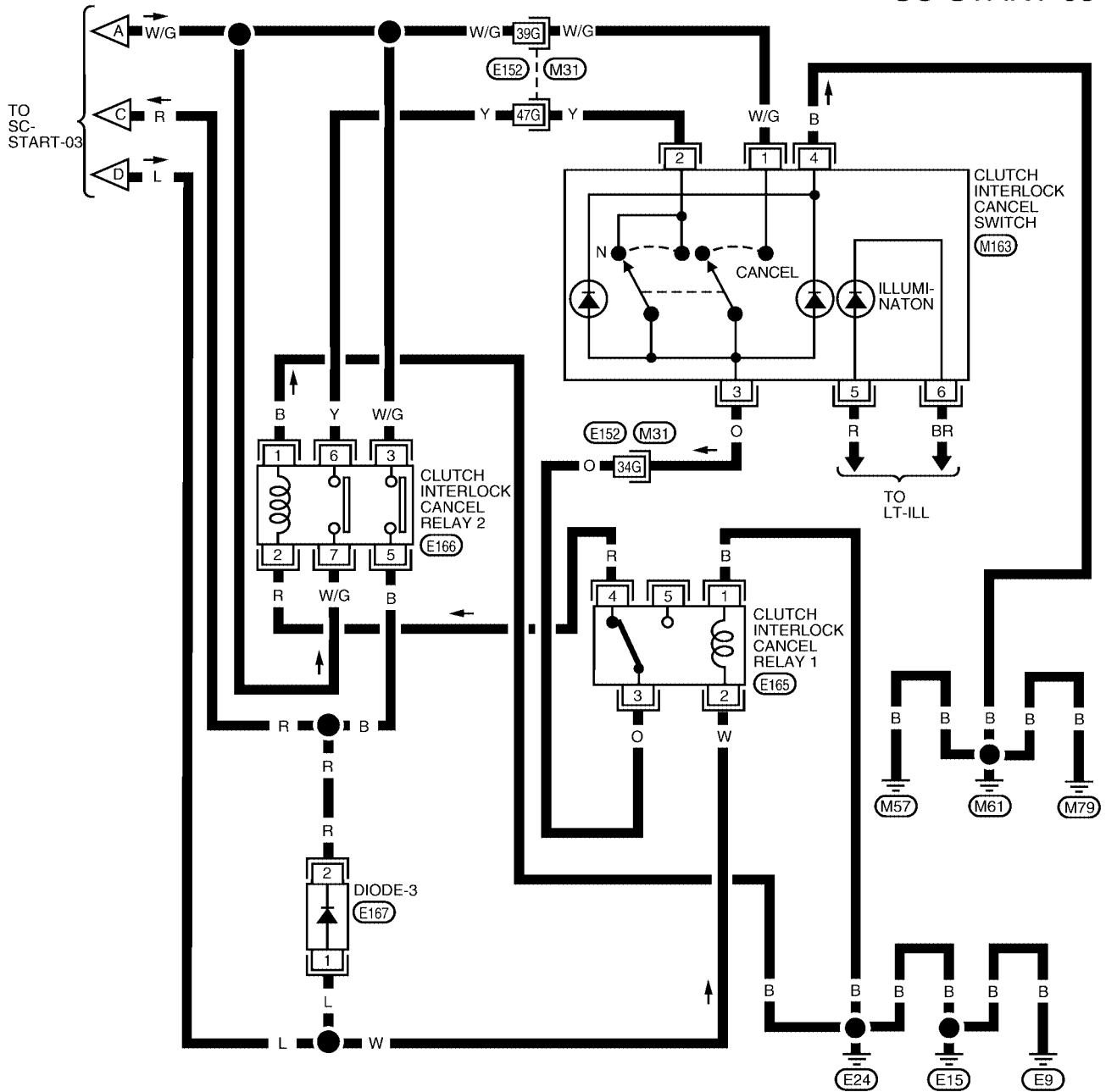

REFER TO THE FOLLOWING.
(M31) - SUPER MULTIPLE JUNCTION (SMJ)

WKWA2479E

STARTING SYSTEM

EKS00E27

Trouble Diagnoses with Battery/Starting/Charging System Tester

NOTE:

To ensure a complete and thorough diagnosis, the battery, starter and generator test segments must be done as a set from start to finish.

1. Turn off all loads on the vehicle electrical system.
2. Perform battery test with Battery/Starting/Charging system tester. Refer to [SC-6, "Trouble Diagnoses with Battery/Starting/Charging System Tester"](#) .
3. Press "ENTER" to begin the starting system test.

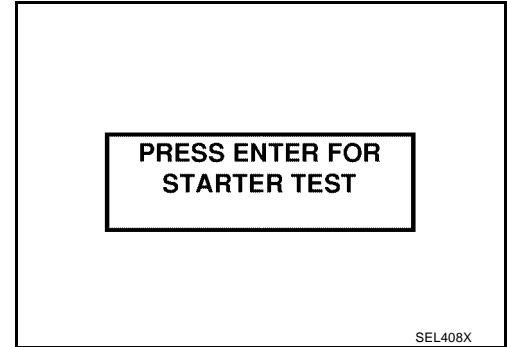

4. Start the engine.

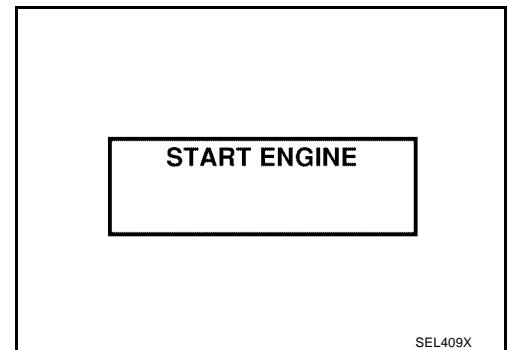

5. Diagnosis result is displayed on the tester. Refer to [SC-8, "DIAGNOSTIC RESULT ITEM CHART"](#) .

NOTE:

- If the starter performs normally but the engine does not start, perform engine diagnosis.
- For intermittent "NO CRANK" or "NO STARTER OPERATION" incidents, refer to [SC-21, "DIAGNOSTIC PROCEDURE 2"](#) .

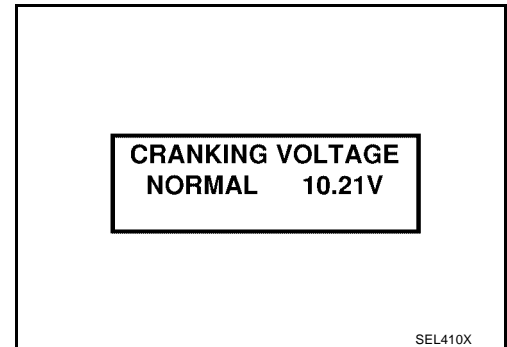

DIAGNOSTIC RESULT ITEM CHART

Diagnostic item	Service procedure
CRANKING VOLTAGE NORMAL	Go to SC-19, "WORK FLOW" .
CRANKING VOLTAGE LOW	
CHARGE BATTERY	Perform the slow battery charging procedure. (Initial rate of charge is 10A for 12 hours.) Perform battery test again with Battery/Starting/Charging system tester. Refer to SC-6, "Trouble Diagnoses with Battery/Starting/Charging System Tester" .
REPLACE BATTERY	Before replacing battery, clean the battery cable clamps and battery posts. Perform battery test again with Battery/Starting/Charging system tester. Refer to SC-6, "Trouble Diagnoses with Battery/Starting/Charging System Tester" . If second test result is "REPLACE BATTERY", then do so. Perform battery test again to confirm repair.

STARTING SYSTEM

WORK FLOW

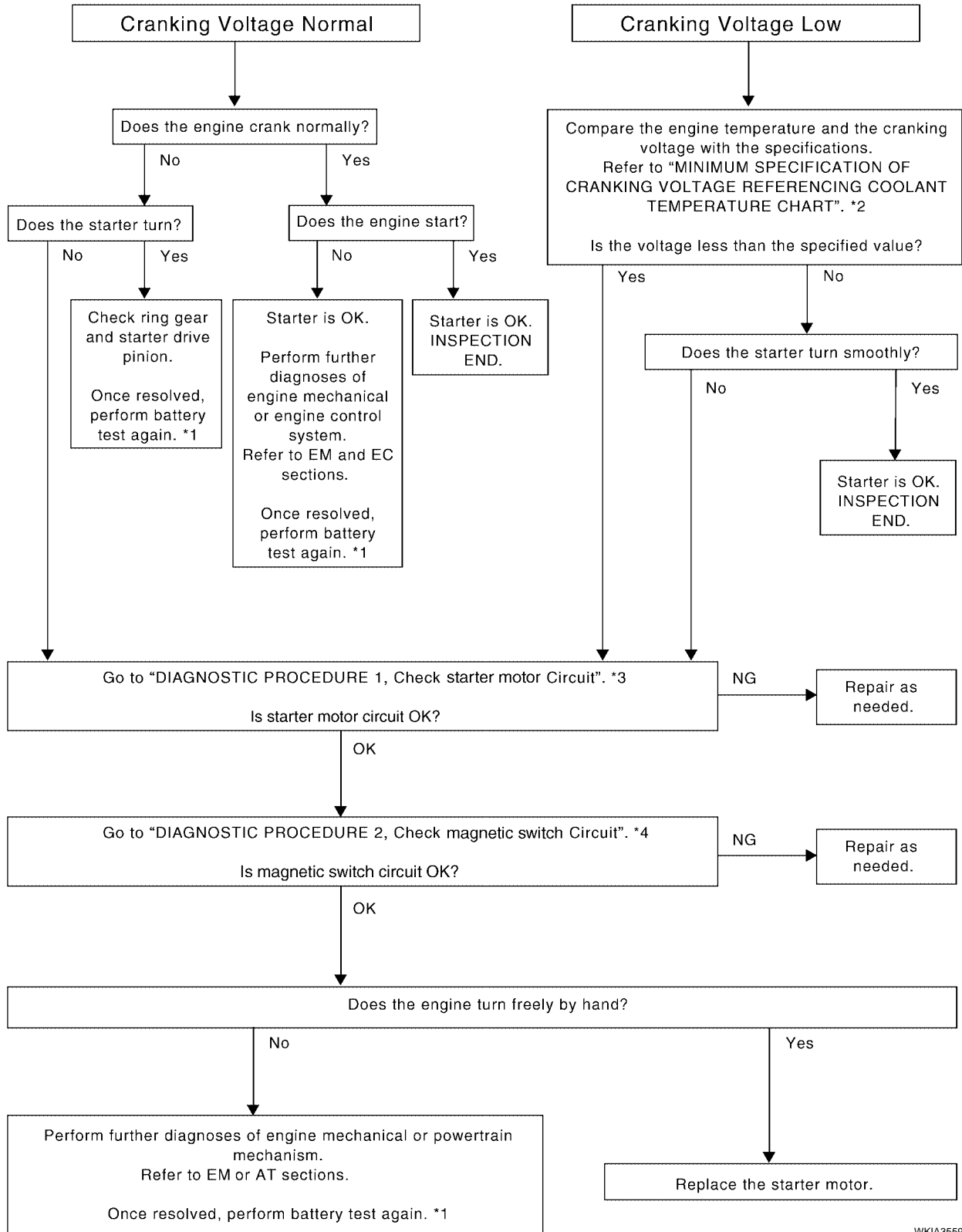

*1 [SC-6](#)

*2 [SC-22](#)

*3 [SC-20](#)

*4 [SC-21](#)

WKIA3559E

STARTING SYSTEM

DIAGNOSTIC PROCEDURE 1

Check Starter Motor Circuit

1. CHECK POWER SUPPLY TO STARTER MOTOR

1. Remove the fuel pump fuse.
2. Crank or start the engine (where possible) until the fuel pressure is released.
3. Turn the ignition switch OFF.
4. Check that the starter motor connector F27 connection is clean and tight.
5. Check voltage between starter motor connector F27 terminal 2 and ground using a digital circuit tester.

Battery voltage should exist.

OK or NG

OK >> GO TO 2.

NG >> Check harness between the battery and the starter motor for open circuit.

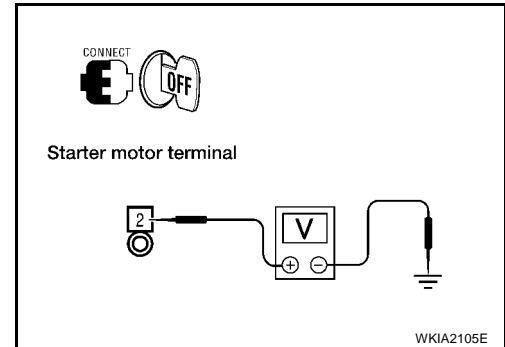

2. CHECK VOLTAGE DROP ON STARTER MOTOR CIRCUIT

Check voltage between starter motor connector F27 terminal 2 and battery positive terminal using a digital circuit tester.

Ignition switch in START. : Less than 0.5V

OK or NG

OK >> GO TO 3.

NG >> Check harness between the battery and the starter motor for poor continuity.

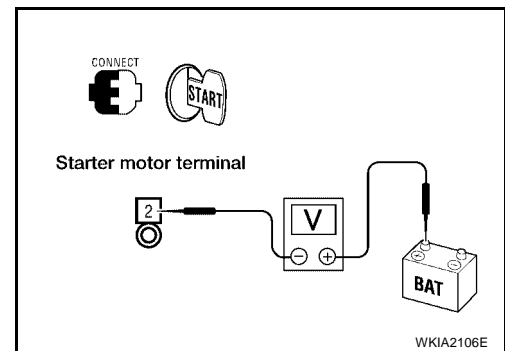

3. CHECK VOLTAGE DROP ON STARTER MOTOR GROUND CIRCUIT

Check voltage between starter motor case and battery negative terminal using a digital circuit tester.

Ignition switch in START. : Less than 0.2V

OK or NG

OK >> Starter motor ground circuit is OK. Further inspection is necessary. Refer to [SC-19, "WORK FLOW"](#).

NG >> Check harness between the starter motor case and ground for poor continuity.

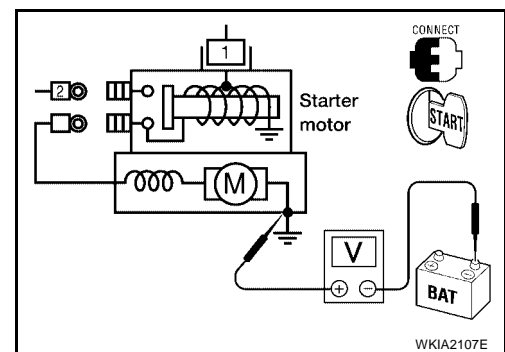

STARTING SYSTEM

DIAGNOSTIC PROCEDURE 2

Check Magnetic Switch Circuit

1. CHECK POWER SUPPLY FOR MAGNETIC SWITCH

1. Remove the fuel pump fuse.
2. Crank or start the engine (where possible) until the fuel pressure is released.
3. Turn the ignition switch OFF.
4. Disconnect starter motor connector E207.
5. Check voltage between starter motor connector E207 terminal 1 and ground using a digital circuit tester.

Ignition switch in START. : **Battery voltage**

OK or NG

OK >> GO TO 2.

NG >> Check the following.

- 40A fusible link (No. **j** , located in fuse and fusible link box)
- 10A fuse [No. **49** , located in the intelligent power distribution module engine room (IPDM E/R)]
- Ignition switch
- Starter relay [within the intelligent power distribution module engine room (IPDM E/R)]
- Harness for open or short
- Clutch interlock switch (M/T models)

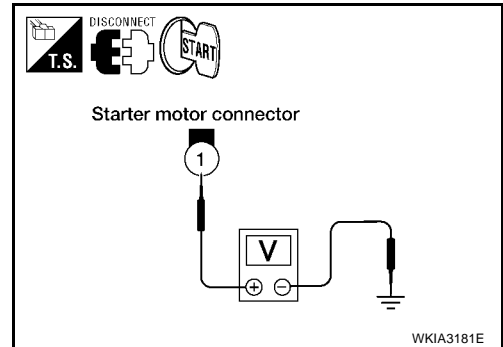

2. CHECK VOLTAGE DROP ON MAGNETIC SWITCH CIRCUIT

1. Turn the ignition switch OFF.
2. Connect starter motor connector E207.
3. Check voltage between starter motor connector E207 terminal 1 and battery positive terminal using a digital circuit tester.

Ignition switch in START. : **Less than 1V**

OK or NG

OK >> Magnetic switch circuit is OK. Further inspection is necessary. Refer to [SC-19, "WORK FLOW"](#) .

NG >> Check harness between the battery and the magnetic switch for poor continuity.

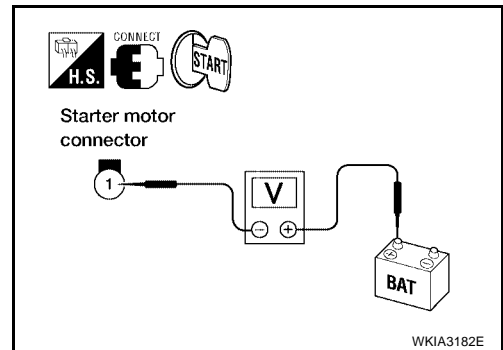

STARTING SYSTEM

MINIMUM SPECIFICATION OF CRANKING VOLTAGE REFERENCING COOLANT TEMPERATURE

Engine coolant temperature	Voltage V
-30°C to -20°C (-22°F to -4°F)	8.4
-19°C to -10°C (-2°F to 14°F)	8.9
-9°C to 0°C (16°F to 32°F)	9.3
More than 1°C (More than 34°F)	9.7

Removal and Installation

EKS00D8T

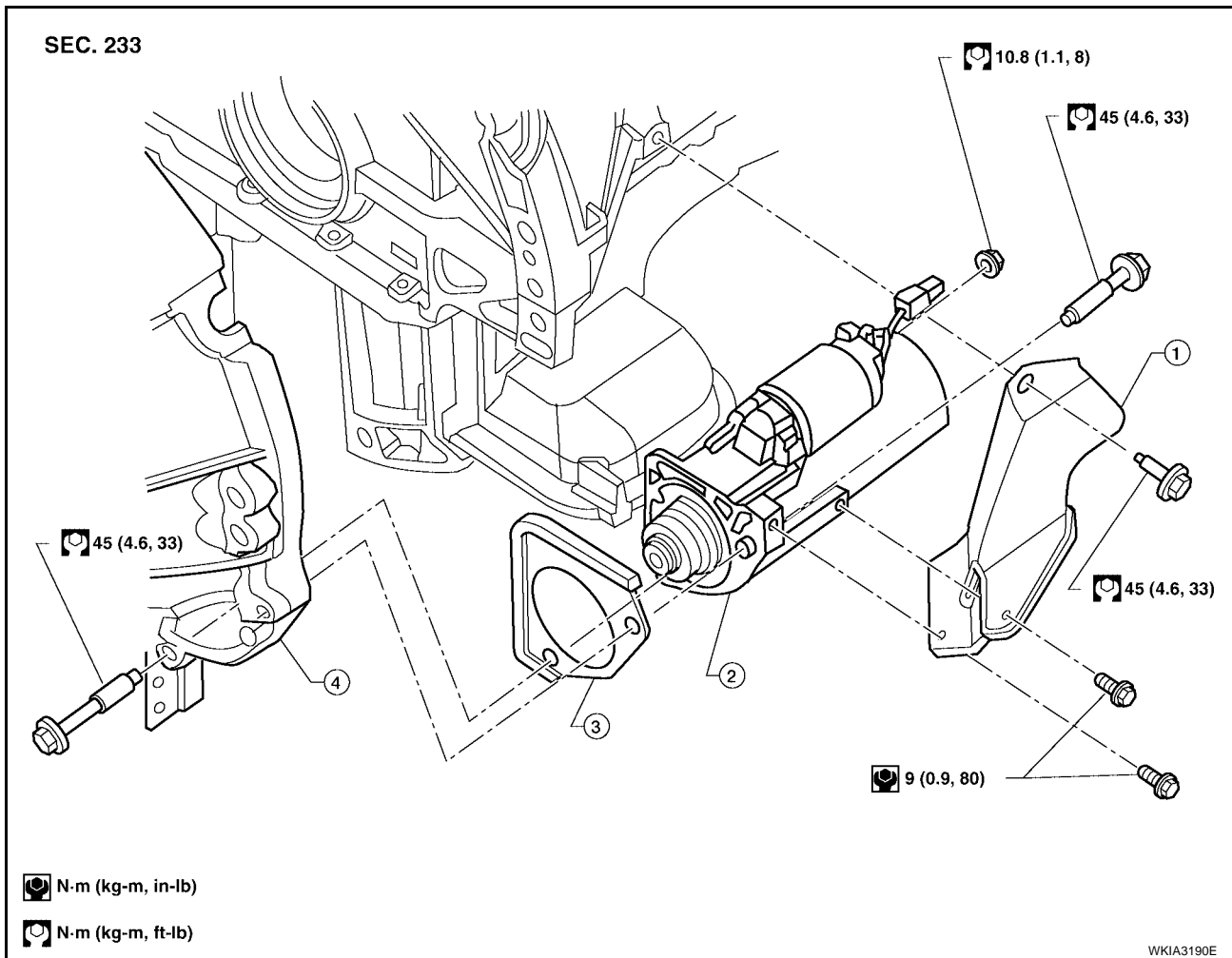

1. Starter cover
2. Starter motor assembly
3. Starter cover plate (rear)
4. Transmission housing

REMOVAL

1. Disconnect the negative battery terminal.
2. Remove engine undercover, using power tools.
3. Remove exhaust manifold cover from exhaust manifold (bank 1) to gain access to starter cover bolts. Refer to [EX-4, "REMOVAL"](#).
4. Remove starter cover bolts and starter cover.

STARTING SYSTEM

5. Disconnect terminal "1" connector and terminal "2" nut.
6. Remove the two starter bolts, using power tools.
7. Remove the starter.

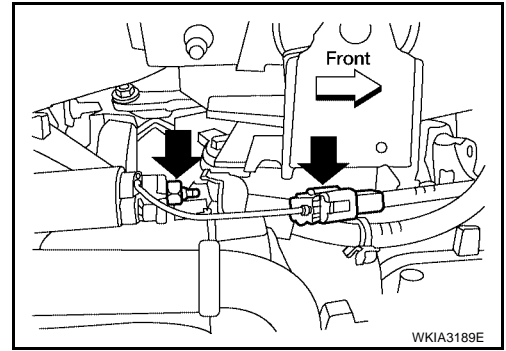

INSTALLATION

Installation is in the reverse order of removal.

Terminal "2" nut : 10.8 N·m (1.1 kg-m, 8 ft-lb)

CAUTION:

Be sure to tighten terminal "2" nut carefully.

A
B
C
D
E
F
G
H
I
J
SC
L
M

CHARGING SYSTEM

CHARGING SYSTEM

PFP:23100

System Description

EKS00E28

The generator provides DC voltage to operate the vehicle's electrical system and to keep the battery charged. The voltage output is controlled by the IC regulator.

Power is supplied at all times to generator terminal 3 through:

- 15A fuse (No. 30, located in the fuse and fusible link box).

Terminal 1 supplies power to charge the battery and operate the vehicle's electrical system. Output voltage is controlled by the IC regulator at terminal 3 detecting the input voltage. A pulse width modulated (PWM) signal is sent from terminal 37 of the IPDM E/R to terminal 4 of the generator. The ECM determines the duty cycle of the power generation variable voltage control system. The charging circuit is protected by the 140A fusible link [No. a , located in the fusible link box (battery)].

The generator is grounded through the engine.

With the ignition switch in the ON or START position, power is supplied:

- through 10A fuse [No. 14, located in the fuse block (J/B)]
- to combination meter terminal 16 for the charge warning lamp.

Ground is supplied to terminal 2 of the combination meter through terminal 2 of the generator. With power and ground supplied, the charge warning lamp will illuminate. When the generator is providing sufficient voltage with the engine running, the ground is opened and the charge warning lamp will go off. If the charge warning lamp illuminates with the engine running, a fault is indicated. The IC regulator warning function activates to illuminate "CHARGE" warning lamp, if any of the following symptoms occur while generator is operating:

- Excessive voltage is produced.
- No voltage is produced.

POWER GENERATION VARIABLE VOLTAGE CONTROL SYSTEM

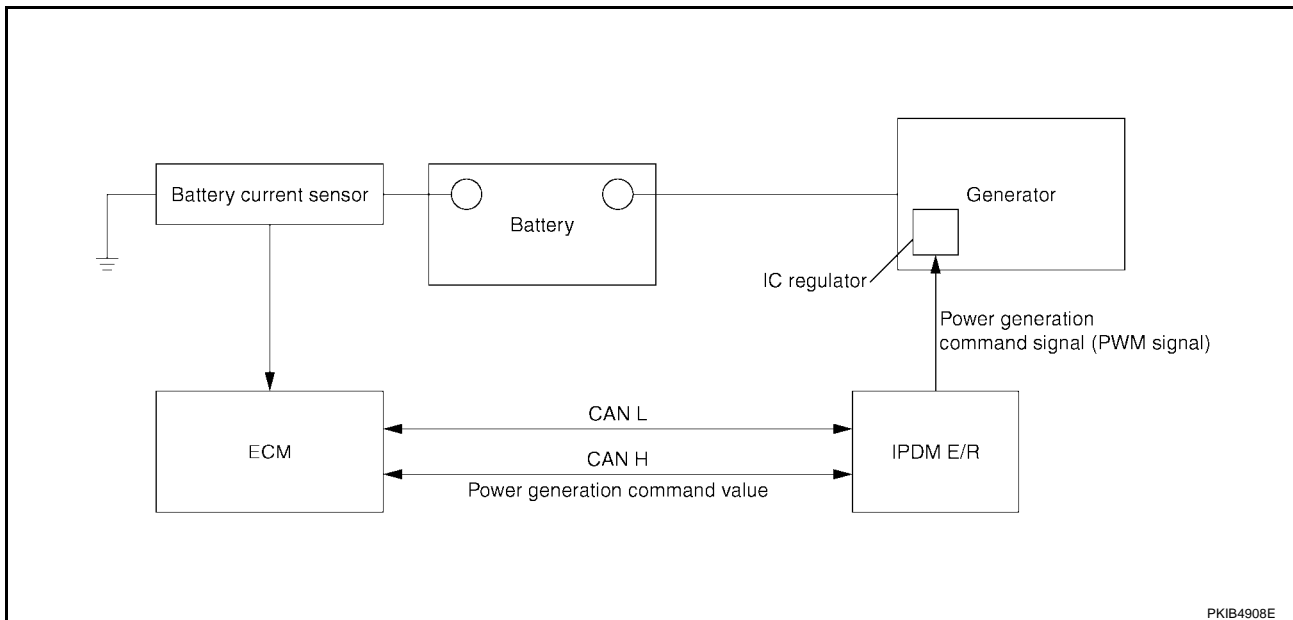

NOTE:

Power generation variable voltage control system has been adopted. By varying the voltage to the generator, engine load due to power generation of the generator is reduced and fuel consumption is decreased.

Operation

- The battery current sensor detects the charging/discharging current of the battery. ECM judges the battery condition based on this signal.
- ECM judges whether to control voltage according to the battery condition.
- ECM calculates the target power generation voltage according to the battery condition and sends the calculated value, through CAN lines, as the power generation command value to IPDM E/R.
- IPDM E/R converts the received power generation command value into the power generation command signal (PWM signal) and sends it to the IC regulator.
- The IC regulator performs final control over the power generation voltage.

CHARGING SYSTEM

- When there is no power generation command signal, the generator performs the normal power generation according to the characteristic of the IC regulator.

NOTE:

When any malfunction is detected in the power generation variable voltage control system, power generation is performed according to the characteristic of the IC regulator in the generator.

Component

BATTERY CURRENT SENSOR

- Battery current sensor is installed to the negative battery cable and it detects the charging/discharging current of the battery and sends the voltage signal to ECM according to the current value.

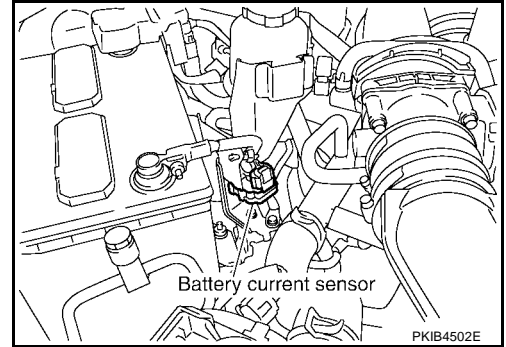

A
B
C
D
E
F
G
H
I
J
L
M

SC

CHARGING SYSTEM

EKS00E29

Wiring Diagram — CHARGE —

SC-CHARGE-01

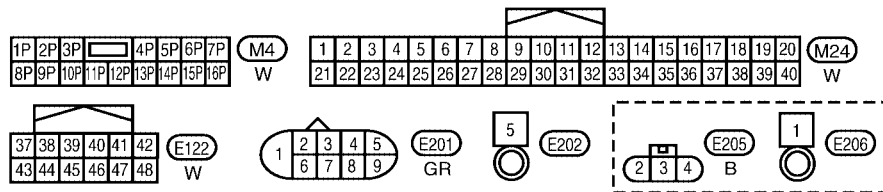
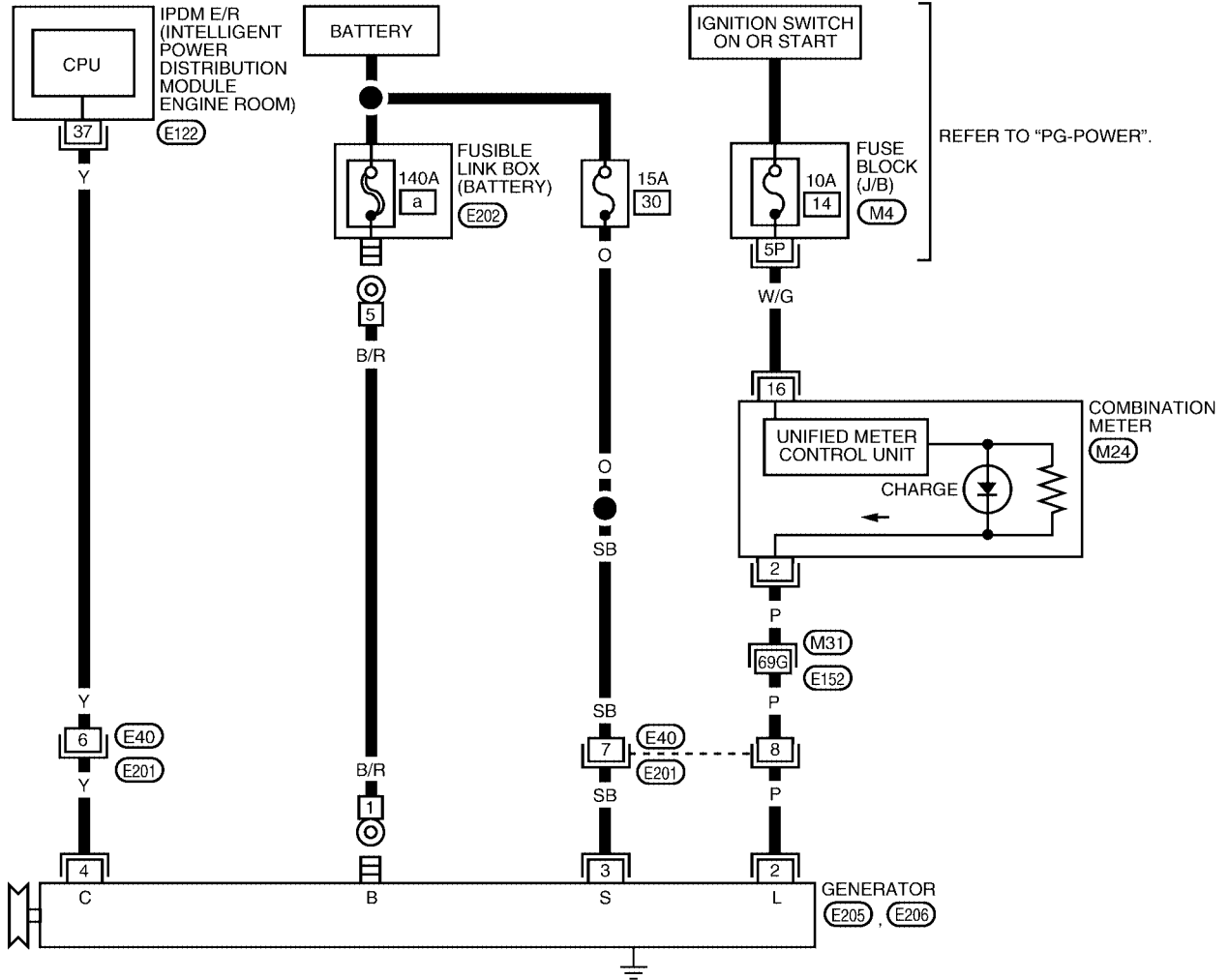

REFER TO THE FOLLOWING.
 (M31) - SUPER MULTIPLE JUNCTION (SMJ)

WKWA2480E

CHARGING SYSTEM

Trouble Diagnoses with Battery/Starting/Charging System Tester

EKS00E2A

NOTE:

To ensure a complete and thorough diagnosis, the battery, starter and generator test segments must be done as a set from start to finish.

Before starting, perform the preliminary inspection. Refer to [SC-30, "PRELIMINARY INSPECTION"](#) .

1. Stop the operation of the power generation variable voltage control system using either of the following procedures.
 - Using the CONSULT-II, select "ENGINE" from "SELECT SYSTEM" and set the "ALT DUTY" to 0%. Keep "ALT DUTY" at 0% until the end of the inspection. When the "ALT DUTY" value is 0% or 100%, normal power generation is performed according to the characteristic of the IC regulator in the generator.
 - Turn the ignition switch off, and disconnect the battery current sensor connector. Disconnecting the battery current sensor may cause DTC (P1550 - P1554) to set. After finishing the inspection, connect the battery current sensor connector and erase the self-diagnostic results history of the engine using CONSULT-II.
2. Turn off all loads on the vehicle electrical system.
3. Perform battery and starting system test with Battery/Starting/Charging system tester.
4. Press "ENTER" to begin the charging system test.
5. Start engine.

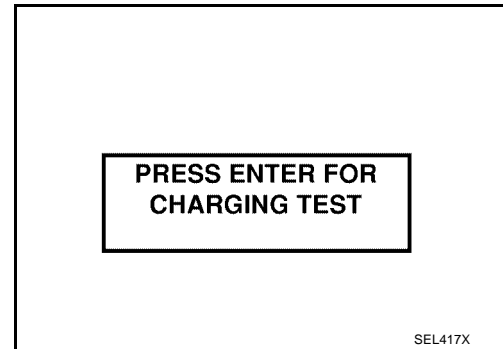

6. Press "ENTER" until "LOADS OFF REV ENGINE 5 SEC" is displayed.
7. Raise and hold the engine speed at 1,500 to 2,000 rpm for about 5 seconds, then return the engine to idle. Once the increase in engine rpm is detected, press "ENTER" to continue.

NOTE:

- If after 30 seconds an increase in engine idle speed is not detected, "RPM NOT DETECTED" will display.
- Some engines may have a higher idle initially after starting, particularly when the engine is cold. The tester may detect this without any other action being taken. If this occurs, continue on with the testing process. The final results will not be affected.

8. The tester now checks the engine at idle and performs the DIODE/RIPPLE check.
9. When complete, the tester will prompt you to turn on the following electrical loads.
 - Heater fan set to highest speed. Do not run the A/C or windshield defroster.
 - Headlamp high beam
 - Rear window defogger

NOTE:

Do not run the windshield wipers or any other cyclical loads.

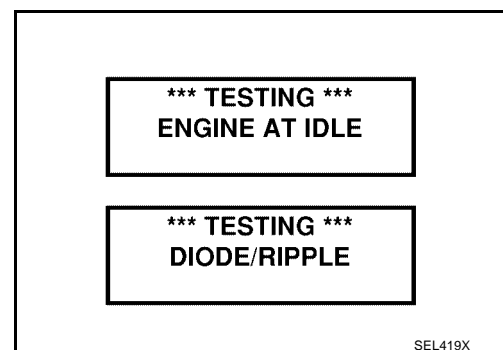
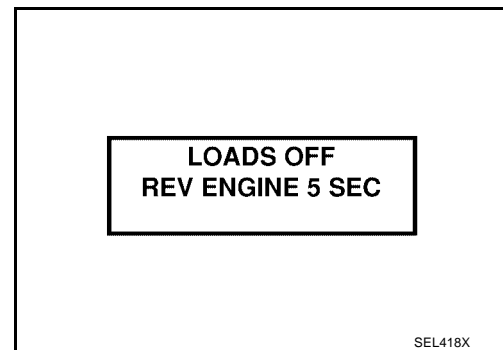

CHARGING SYSTEM

10. Press "ENTER" to continue.

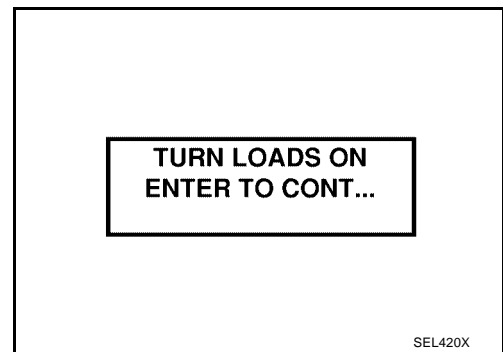

11. Raise and hold the engine speed at 1,500 to 2,000 rpm for about 5 seconds, then return the engine to idle. Once the increase in engine rpm is detected, press "ENTER" to continue.

NOTE:

If after 30 seconds an increase in engine idle speed is not detected, "RPM NOT DETECTED" will be displayed. Press "ENTER" to restart the test.

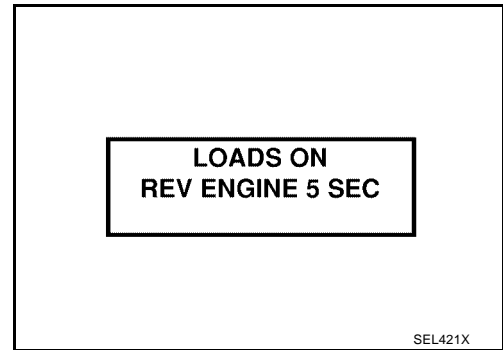

12. Diagnostic result is displayed on the tester. Refer to [SC-28](#), "[DIAGNOSTIC RESULT ITEM CHART](#)".

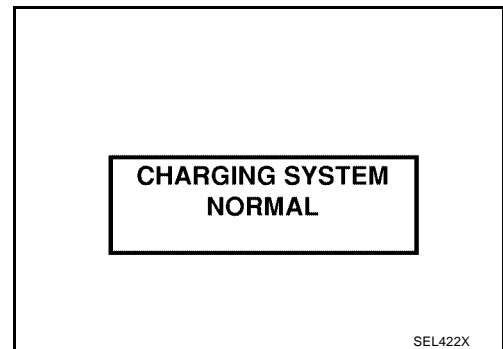

13. Press "ENTER" then test output code is displayed. Record the test output code on the repair order.

14. Toggle back to the "DIAGNOSTIC SCREEN" for test results.

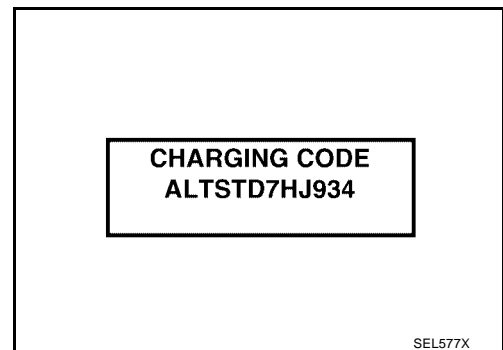

DIAGNOSTIC RESULT ITEM CHART

Diagnostic item	Service procedure
CHARGING SYSTEM NORMAL	Charging system is normal and will also show DIODE RIPPLE test result.
NO CHARGING VOLTAGE	Go to SC-29 , " WORK FLOW ".
LOW CHARGING VOLTAGE	
HIGH CHARGING VOLTAGE	
DIODE RIPPLE NORMAL	Diode ripple is OK and will also show CHARGING VOLTAGE test result.

CHARGING SYSTEM

Diagnostic item	Service procedure
EXCESS RIPPLE DETECTED	Replace the generator. Refer to SC-34, "Removal and Installation" . Perform "DIODE RIPPLE" test again using Battery/Starting/Charging system tester to confirm repair.
DIODE RIPPLE NOT DETECTED	Go to SC-29, "WORK FLOW" .

WORK FLOW

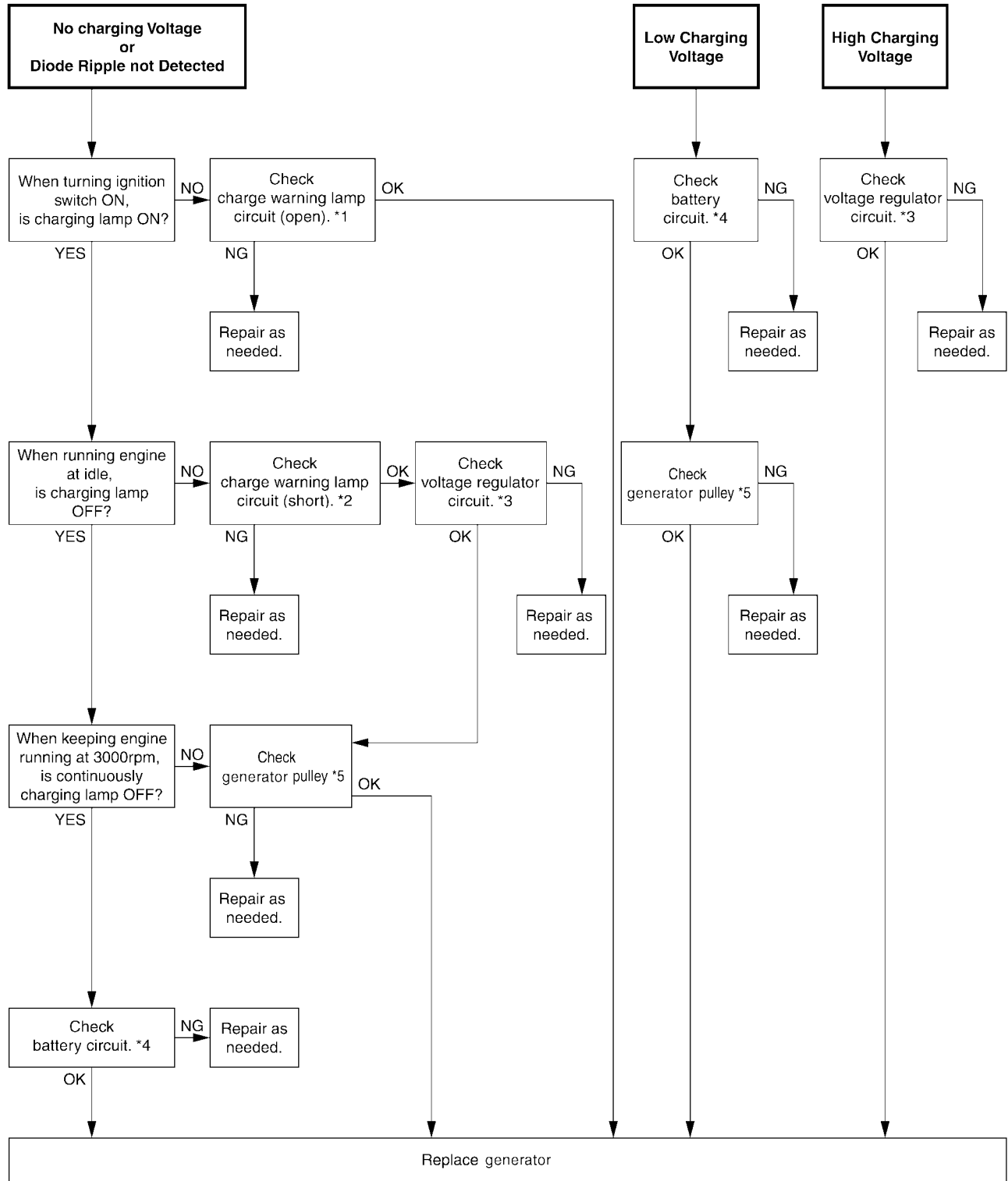

WKIA3717E

CHARGING SYSTEM

*1 [SC-30, "DIAGNOSTIC PROCEDURE 1"](#)

*2 [SC-31, "DIAGNOSTIC PROCEDURE 2"](#)

*3 [SC-31, "DIAGNOSTIC PROCEDURE 3"](#)

*4 [SC-32, "DIAGNOSTIC PROCEDURE 4"](#)

*5 [SC-35, "GENERATOR PULLEY INSPECTION"](#)

PRELIMINARY INSPECTION

1. CHECK BATTERY TERMINALS CONNECTION

Check if battery terminals are clean and tight.

OK or NG

OK >> GO TO 2.

NG >> Repair battery terminal connections.

2. CHECK FUSE AND FUSIBLE LINK

Check for blown fuses and fusible link. Refer to [PG-79, "FUSE AND FUSIBLE LINK BOX"](#) .

Unit	Power source (Power supply terminals)	Fuse or fusible link
Generator	Battery ("1" terminal)	a
	Battery ("3" terminal)	30
Combination meter	Ignition switch ON ("2" terminal)	14

OK or NG

OK >> GO TO 3.

NG >> If fuse is blown, be sure to eliminate cause of malfunction before installing new fuse.

3. CHECK GENERATOR DRIVE BELT TENSION

Check generator drive belt tension. Refer to [EM-13, "Checking Drive Belts"](#) .

OK or NG

OK >> Inspection End.

NG >> Repair as needed.

DIAGNOSTIC PROCEDURE 1

Check Charge Warning Lamp Circuit (Open)

1. CHECK CHARGE WARNING LAMP CIRCUIT CONNECTION

1. Turn the ignition switch OFF.

2. Check terminal 2 harness connector.

OK or NG

OK >> GO TO 2.

NG >> Repair terminal 2 connection. Confirm repair by performing complete Battery/Starting/Charging system test. Refer to [SC-6, "Trouble Diagnoses with Battery/Starting/Charging System Tester"](#) .

CHARGING SYSTEM

2. CHECK CHARGE WARNING LAMP CIRCUIT (OPEN)

1. Disconnect E205 connector from generator.
2. Apply ground to connector E205 terminal 2 with the ignition switch in the ON position.

CHARGE lamp should light up.

OK or NG

OK >> GO TO [SC-29, "WORK FLOW"](#) .

NG >> Check the following.

- Charge warning lamp (Combination meter)
- Harness for open or short between combination meter and fuse
- Harness for open between combination meter and generator

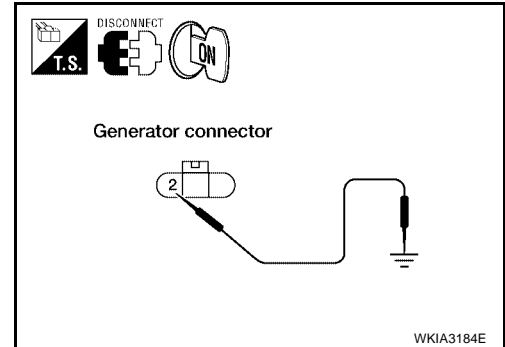

DIAGNOSTIC PROCEDURE 2

Check Charge Warning lamp Circuit (Short)

1. CHECK CHARGE WARNING LAMP CIRCUIT (SHORT)

1. Turn the ignition switch OFF.
2. Disconnect generator connector E205.
3. Turn ignition switch ON.

Does charge warning lamp light up?

YES >> Check the following.

- Harness for short between combination meter and generator
- Charge warning lamp (Combination meter)

NO >> GO TO [SC-29, "WORK FLOW"](#) .

DIAGNOSTIC PROCEDURE 3

Check Voltage Regulator Circuit

1. CHECK VOLTAGE REGULATOR CIRCUIT CONNECTION

1. Turn the ignition switch OFF.
2. Check terminal 3 harness connector.

OK or NG

OK >> GO TO 2.

NG >> Repair terminal 3 connection. Confirm repair by performing complete Battery/Starting/Charging system test. Refer to [SC-6, "Trouble Diagnoses with Battery/Starting/Charging System Tester"](#) .

2. CHECK VOLTAGE REGULATOR CIRCUIT

Check voltage between generator connector E205 terminal 3 and ground using a digital circuit tester.

Battery voltage should exist.

OK or NG

OK >> GO TO [SC-29, "WORK FLOW"](#) .

NG >> Check harness for open between generator and fuse.

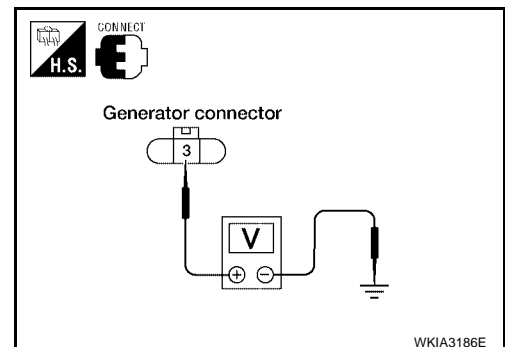

CHARGING SYSTEM

DIAGNOSTIC PROCEDURE 4

Check Battery Circuit

1. CHECK BATTERY CIRCUIT CONNECTION

1. Turn the ignition switch OFF.
2. Check to see if terminal 1 is clean and tight.

OK or NG

OK >> GO TO 2.

NG >> Repair terminal 1 connection. Confirm repair by performing complete Battery/Starting/Charging system test. Refer to [SC-6, "Trouble Diagnoses with Battery/Starting/Charging System Tester"](#) .

2. CHECK BATTERY CIRCUIT

Check voltage between generator connector E206 terminal 1 and ground using a digital circuit tester.

Battery voltage should exist.

OK or NG

OK >> GO TO 3.

NG >> Check harness for open between generator and fusible link.

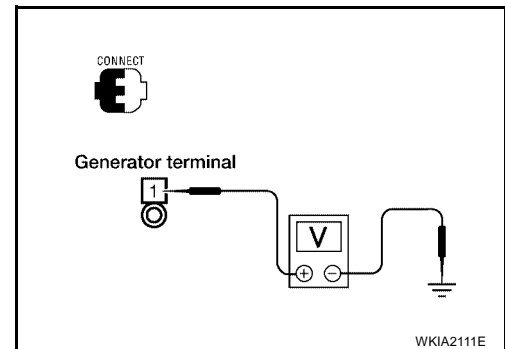

3. CHECK VOLTAGE DROP ON BATTERY CIRCUIT

1. Start engine.
2. While engine is running at idle and warm, check voltage between generator connector E206 terminal 1 and battery positive terminal using a digital circuit tester.

**With engine running : Less than 0.2V
at idle and warm.**

OK or NG

OK >> GO TO [SC-29, "WORK FLOW"](#) .

NG >> Check harness between the battery and the generator for poor continuity.

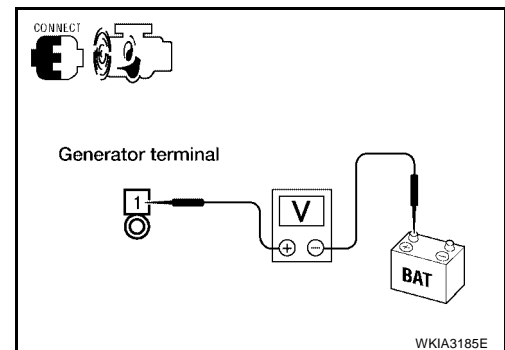

CHARGING SYSTEM

EKS00E2B

Power Generation Variable Voltage Control System Inspection

CAUTION:

- For this model, the battery current sensor that is installed to the negative battery cable measures the charging/discharging current of the battery and performs various engine controls. If an electrical component is connected directly to the negative battery terminal, the current flowing through that component will not be measured by the battery current sensor. This condition may cause a malfunction of the engine control system and battery discharge may occur. Do not connect an electrical component or ground wire directly to the battery terminal.
- When performing this inspection, always use the charged battery that completed the battery inspection. When the charging rate of the battery is low, the response speed of the voltage change will become slow. This is a cause of an incorrect inspection.

INSPECTION PROCEDURE

1. CHECK SELF-DIAGNOSIS OF ECM

CAUTION:

If CONSULT-II is used with no connection of CONSULT-II CONVERTER, malfunction might be detected in self-diagnosis depending on control unit which carries out CAN communication.

Perform ECM self-diagnosis with CONSULT-II.

Self-diagnostic results content

No malfunction detected>>GO TO 2.

Malfunction detected>>Check applicable parts, and repair or replace corresponding parts.

2. CHECK POWER GENERATION VARIABLE VOLTAGE CONTROL SYSTEM OPERATION

- Connect CONSULT-II and CONSULT-II CONVERTER and start the engine.
- Put selector lever in "P" or "N" position (A/T models) and turn all electric loads including A/C OFF.
- Select "ALT DUTY" at "ACTIVE TEST" of "ENGINE", and then check the value of "BATTERY VOLT" when "ALTERNATOR DUTY" is set to 40 %.

"BATTERY VOLT"
seconds after setting **12.0 V - 13.6 V**
"ALTERNATOR DUTY" to
40%

Example)

ACTIVE TEST			
ALTERNATOR DUTY	40.0 %		
MONITOR			
BATTERY VOLT	12.3V		
BAT CUR SEN	2190mV		
Qu	UP	DOWN	Qd
MODE	BACK	LIGHT	COPY

PKIB4503E

- Check the value of "BATTERY VOLT" when "ALTERNATOR DUTY" is set to 80%.

"BATTERY VOLT"
20 seconds after setting **0.5 V or more than the**
"ALTERNATOR DUTY" to **value of "BATTERY**
80% **VOLT" when "ALTERNA-**
TOR DUTY" was 40%

Example)

ACTIVE TEST			
ALTERNATOR DUTY	80.0 %		
MONITOR			
BATTERY VOLT	14.5V		
BAT CUR SEN	2780mV		
Qu	UP	DOWN	Qd
MODE	BACK	LIGHT	COPY

PKIB4504E

OK or NG

OK >> Inspection End.

NG >> GO TO 3. (The charging condition of the battery should be normal.)

CHARGING SYSTEM

3. CHECK SELF-DIAGNOSIS OF IPDM E/R

Perform IPDM E/R self-diagnosis with CONSULT-II.

Self-diagnostic results content

No malfunction detected>>GO TO 4.

Malfunction detected>>Check applicable parts, and repair or replace corresponding parts.

4. CHECK HARNESS BETWEEN IPDM AND GENERATOR

1. Disconnect generator connector E205 and IPDM E/R connector E122.

2. Check continuity between generator harness connector E205 terminal 4 and IPDM E/R harness connector E122 terminal 37.

4 – 37 **Continuity should exist.**

3. Check continuity between generator harness connector E205 terminal 4 and ground.

4 – Ground **Continuity should not exist.**

OK or NG

OK >> Replace IPDM E/R. Refer to [PG-28, "Removal and Installation of IPDM E/R"](#).

NG >> Repair harness or connector between IPDM E/R and generator.

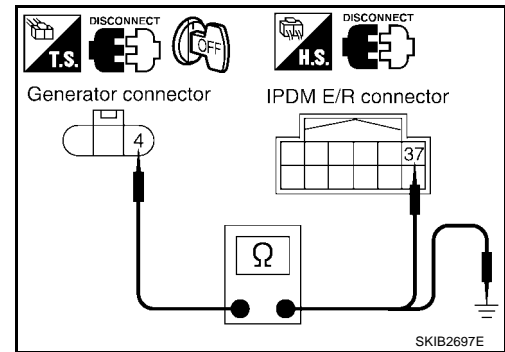

Removal and Installation

EKS00D8Y

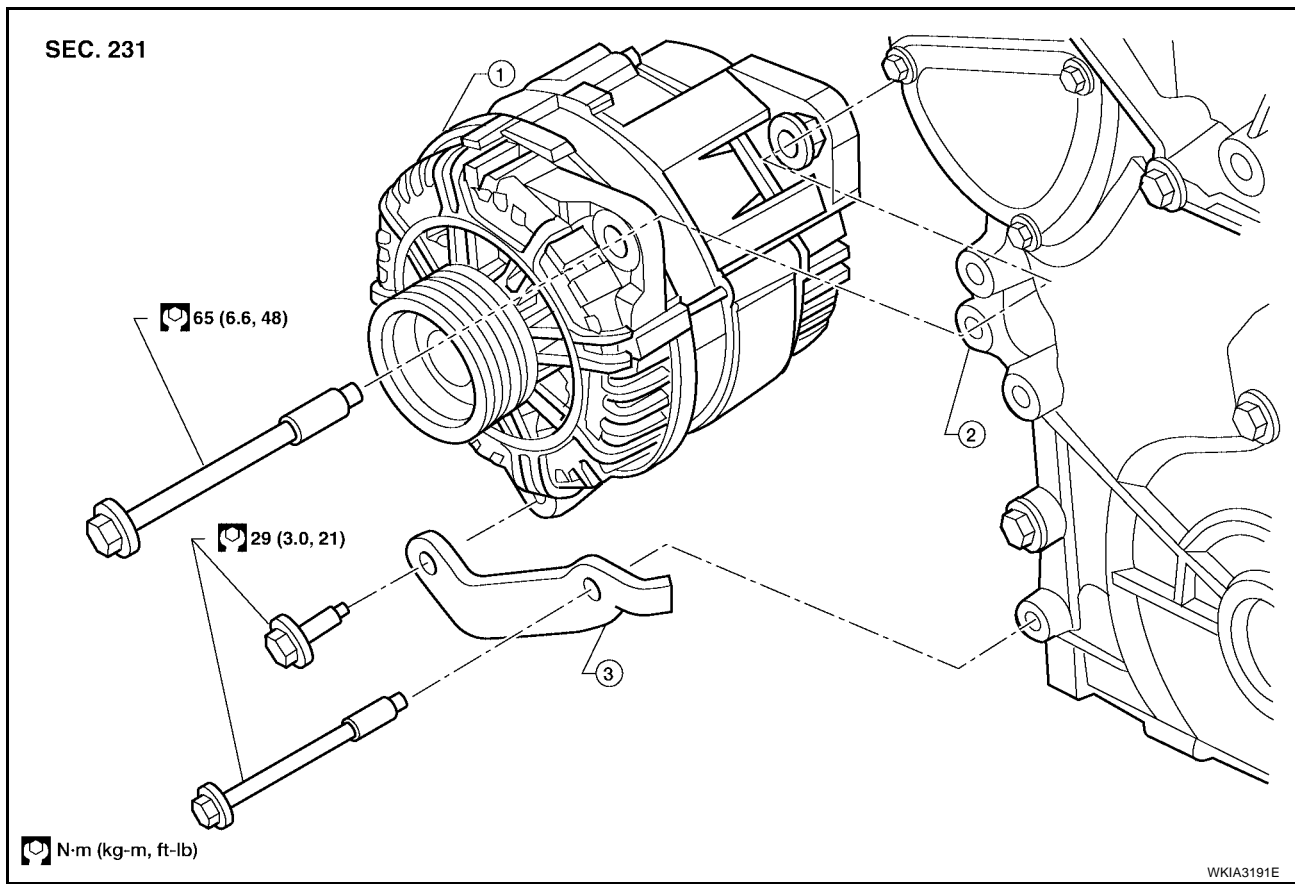

REMOVAL

1. Disconnect the negative battery terminal.

2. Remove the fan shroud. Refer to [CO-11, "Removal and Installation"](#).

CHARGING SYSTEM

3. Remove the drive belt. Refer to [EM-13, "Removal and Installation"](#) .
4. Remove generator stay, using power tools.
5. Remove the generator upper bolt, using power tools.
6. Disconnect the generator harness connectors.
7. Remove the generator.

GENERATOR PULLEY INSPECTION

Perform the following.

- Make sure that the generator pulley does not rattle.
- Make sure that the generator pulley nut is properly tightened.

Generator pulley nut : 118 N·m (12.0 kg-m, 87 ft-lb)

INSTALLATION

Installation is in the reverse order of removal.

- Install the generator and check tension of drive belt. Refer to [EM-13, "Tension Adjustment"](#) .

Terminal "1" nut : 10.8 N·m (1.1 kg-m, 8 ft-lb)

CAUTION:

Be sure to tighten terminal "1" nut carefully.

- For this model, the power generation voltage variable control system that controls the power generation voltage of the generator has been adopted. Therefore, the power generation variable voltage control system operation inspection should be performed after replacing the generator, and then make sure that the system operates normally. Refer to [SC-33, "Power Generation Variable Voltage Control System Inspection"](#) .

A

B

C

D

E

F

G

H

I

J

SC

L

M

SERVICE DATA AND SPECIFICATIONS (SDS)

SERVICE DATA AND SPECIFICATIONS (SDS)

PFP:00030

Battery

EKS00D8Z

	Standard battery
Type	Gr. 24
Capacity (20 HR) minimum V-AH	63
Cold cranking current A (For reference value)	550

Starter

EKS00D90

Application	All models	
Manufacturer	Mitsubishi M002T85571ZCKD	
Type	Reduction gear type	
System voltage	12V	
No-load	Terminal voltage	11V
	Current	Less than 120A
	Revolution	More than 3,100 rpm
Minimum diameter of commutator	31.4 mm (1.236 in)	
Minimum length of brush	11.0 mm (0.433 in)	
Brush spring tension	26.7-36.1 N (2.72 - 3.68 kg, 5.93 - 8.02 lb)	
Clearance between pinion front edge and pinion stopper	0.5 - 2.0 mm (0.020 - 0.079 in)	

Generator

EKS00D91

Type	LR1130-701	LR1110-725
	Hitachi	
Nominal rating	12V-130A	12V-110A
Ground polarity	Negative	
Minimum revolution under no-load (When 13.5 volts is applied)	1,200 rpm	1,100 rpm
Hot output current (When 13.5 volts is applied)	More than 78A/1,800 rpm More than 108A/2,500 rpm More than 130A/5,000 rpm	More than 70A/1,800rpm More than 91A/2,500rpm More than 110A/5,000rpm
Regulated output voltage	14.1 - 14.7V @ 20°C	
Minimum length of brush	6 mm (0.24 in)	
Brush spring pressure	1.0 - 3.432 N (0.102 - 0.3501 kg, 0.22 - 0.7715 lbs)	
Slip ring minimum outer diameter	26 mm (1.02 in)	
Rotor (Field coil) resistance	2.1 ohms	
Adjustment range of power generation voltage variable control	11.4-15.6V	