

Section 3

Electrical Diagnostic Tools



- Learning Objectives:**
1. Explain what to look for when making a visual inspection.
 2. Show the proper techniques for using a jumper wire.
 3. Explain the advantages and features of Digital Multimeters.
 4. Explain how to use a voltmeter to make open circuit and voltage drop measurements.
 5. Explain how to use a digital ammeter, both series and inductive types.
 6. Explain how to use a digital ohmmeter for resistance, continuity, and diode checks.
 7. Perform on-car worksheets using all of the functions of the DVOM.



Notes

Introduction After looking at a problem circuit on the EWD, you will need to determine if different components, connections, or wires are OK by making an on-car inspection. There are five circuit inspection tools that will be covered in this section:

- Visual
- Jumper Wires
- Digital Multimeter
 - Voltmeter
 - Ammeter
 - Ohmmeter

Visual Inspection An important part of any diagnostic procedure is to **make a visual inspection** of the vehicle. A visual inspection can quickly catch the simple problems which may be related to the customer's complaint.

Operate the Circuit Thoroughly Read the **EWD system outline** to find out *how the circuit is supposed to operate*. Then operate the circuit and determine exactly what is and what is not working.

This information can save a lot of time. With the help of the EWD, you can narrow down *on paper* the areas you will need to inspect first. By tracing the paths of current flow on the parts of the circuit that work, you can eliminate areas of the circuit that **are not** causing the problem.

EWD System Outline

Read the System Outline to find out how the circuit is supposed to work. Then thoroughly test the circuit, operating as many features/functions as possible.

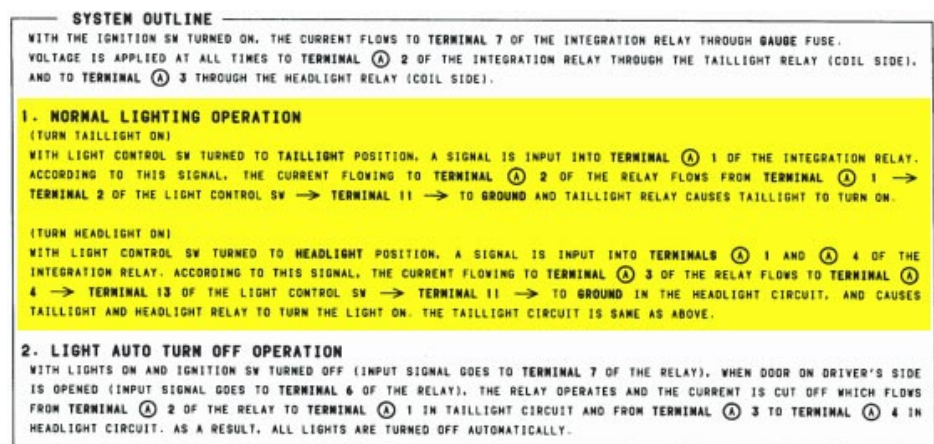

Fig. 3-1
L6521301

Checking Connectors & Terminals

Connector problems are one of the most frequent causes of electrical problems. Typical problems include:

- Connectors not “locked”
- Terminals backed out/not seated
- Corrosion or moisture
- Excessive terminal spread

Excessive Terminal Spread

This problem is one of the most difficult to detect, especially when the female terminal mates directly to a component or ECU. To check the “fit” of the female terminal you can either use a new male terminal from the *Lexus Wire Harness Repair Kit* or use the **Lexus Terminal Tension Gauge SST**.

NOTE

When diagnosing the cause of an intermittent problem, make your inspections *strategically*. Keep in mind that disconnecting connectors or moving the position of wires and harnesses can cause the problem to temporarily “fix” itself. There is no “magic” to electricity; be sure to isolate and repair the cause of the problem.

Terminal Problems

Typical terminal problems include a poor crimp of the wire to a terminal, and terminal tension or spread. The terminal can be checked using the Terminal Tension Gauge SST. If the contact at the terminal is loose, you can be fooled when you backprobe the terminal at the component—the voltmeter reads voltage, but the pin isn’t feeding it to the component.

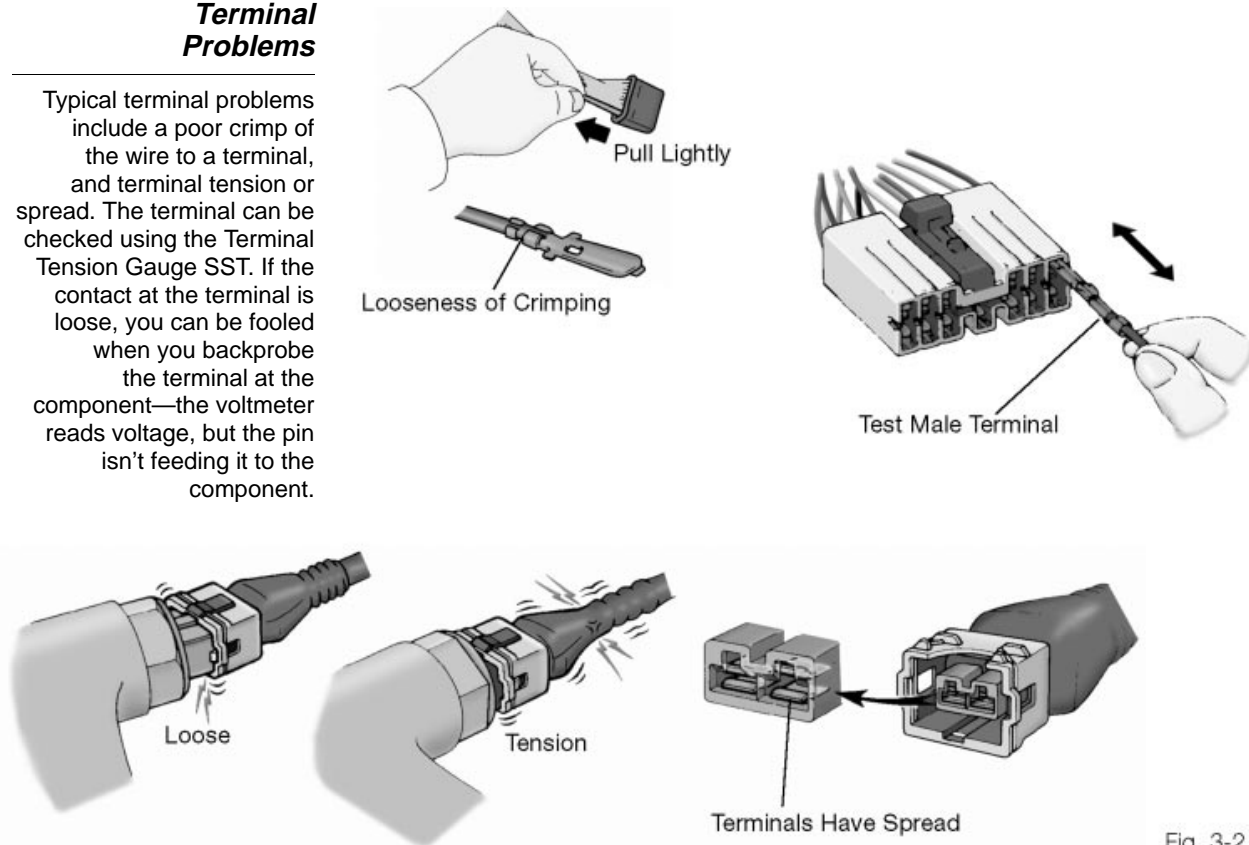

Fig. 3-2
L652F302

Wire Harness Inspection

Typical wire harness problems include:

- **Wires chafing or rubbing:** If a harness is mis-routed, the wire wrap and insulation may rub through, exposing the bare wire for a potential short-to-ground.
- **Harness stretched too tightly:** This condition can cause an open circuit problem that will be difficult to detect. Because of excessive tension on the harness, the wire strands break away from the terminal crimp or break internally. When this happens, the insulation of the wire will look normal, the wire strands will be open. You can check for this condition by squeezing the insulation adjacent to the terminal, feeling for any “soft” spots.
- **Abnormal Kinks or bends:** Sharp bends in the wiring harness, particularly where the wire is subject to repeated flexing, can cause an internal break of the wire strands.

Wire Harness Problems

Look for chafing, sharp bends, and harnesses that are stretched too tightly.

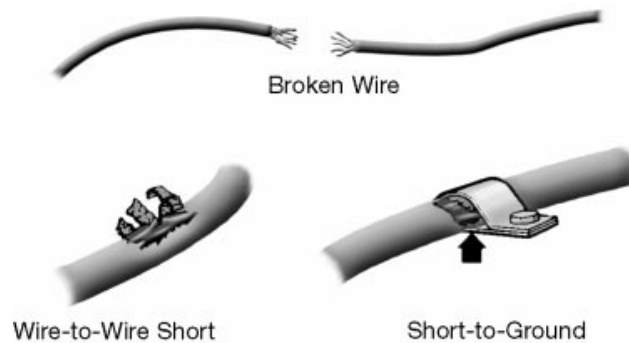

Fig. 3-3
L652f303

Visual Inspection Hints

Visual inspection hints:

1. **Know how the system or circuit is supposed to operate.** This is extremely important, especially with the increased use of ECU controls. Because these small computers have *logic* functions, they are designed to operate *only under certain conditions*. You can find under what conditions the ECU will (or will not) operate the circuit by reading the **System Outline** in the EWD. This will prevent you from looking for a problem that doesn't exist.
2. **Check those items that are easiest to access first.** The “easy ones” may or may not be the cause of the problem, but as a time saving strategy, this is probably the best approach. Connectors or components that are hard to access should be checked on an “as needed” basis.

3. **Use your experience with past problems to help determine where to look first.** Diagnosing a problem is a process of elimination. If the list of possible causes is long, using your past experience can give you an “edge” in tracking down the problem quickly. While your past experience with a similar problem may not be the “fix” for the vehicle you are working on, it can at least give you a starting point which will lead you to the cause of the problem.

Jumper Wires

A simple **jumper wire** can be a very useful tool when diagnosing an electrical problem. A jumper wire, when used in conjunction with the EWD or Repair Manual, provides a quick way to check the operation of a circuit by *bypassing specific sections of wiring, switches, or components*. By eliminating parts of the circuit, or by applying voltage and/or ground directly to the load, you can isolate the exact location of a problem.

CAUTION

- To prevent circuit damage from an accidental short-to-ground, **only use a fused jumper wire**, heavy enough to handle the load you are operating.
- **Never by-pass the LOAD.** This will create a direct short-to-ground in the circuit. Use the EWD or RM to determine where to connect the jumper wire.

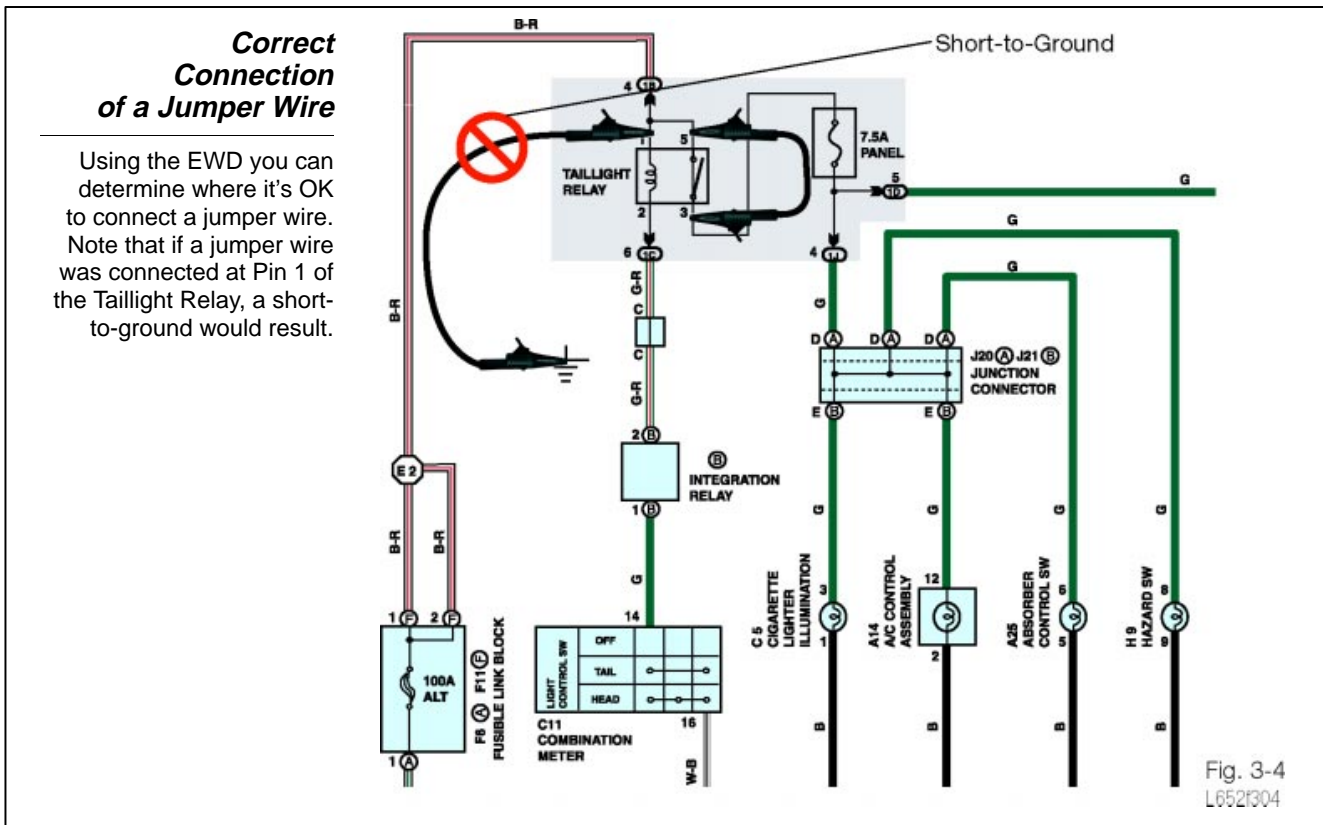

Digital Multimeters

With the introduction of oxygen sensors into the fuel control systems of vehicles in the early 1980s, we were also introduced to the use of **digital multimeters**. These early meters were bulky and relatively expensive, when compared to analog meters.

Digital multimeters are now fairly commonplace. With DVOMs available at about the same price as analog meters, the DVOM is definitely the best measurement tool for general electrical diagnosis. The advantages to using a DVOM over an analog meter are:

- **Easier to use:** “Auto-ranging” meters self-adjust to the range needed for a specific measurement. This is particularly helpful when measuring resistance values.
- **Accuracy:** Because of the high internal resistance (or *high impedance*) of most DVOMs, the accuracy of the meter is increased. The small *power supplies* that are built into many ECUs or the voltage produced by the O2 Sensor will be affected by the **load** placed from the voltmeter. If the voltmeter draws too much current (low internal resistance), the circuit voltage is “pulled” low, causing the measurement to be inaccurate. Since most DVOMs have at least 10 MΩ of resistance built-in, their affect on the circuit voltage is very minimal.
- **Not sensitive to polarity:** When using the voltmeter, the probes can be connected in *reverse polarity* without affecting the accuracy of the reading or damaging the meter. The meter will indicate this reverse polarity condition by placing a “-” symbol in the display.
- **Durability:** Most good quality meters can withstand a substantial amount of shock without damage.
- **Long battery life:** Batteries can last in excess of 200 service hours on DVOMs. Some models also have an automatic shut-off feature.

Digital Multimeters (DVOM)

The Digital Voltmeter (DVOM) comes in a variety of configurations and price ranges. A good general purpose meter can be purchased for less than \$100, with the full featured meters ranging from \$200 to \$400.



Fig. 3-5
L652F305

Additional Meter Features

Many good quality DVOMs have additional features that can be helpful when diagnosing difficult problems:

- **“Min-Max”:** Holds in memory a maximum or minimum voltage or amperage value measured over a period of time. This is extremely helpful to identify a problem such as an intermittent +B or ground connection.
- **Analog Bar Graph:** Most digital displays *refresh* or update about 2 times a second. However, some electrical problems (especially in ECU controlled circuits) can be sensitive to electrical “glitches” that can happen in less than 100 mSec. In the past, an *oscilloscope* was needed identify these problems. With an Analog Bar Graph feature, some DVOMs can show a voltage change happening up to 50 times a second.

While DVOMs have a lot of useful features to help you in diagnosing electrical problems, one major drawback is that these meters are not necessarily user-friendly. Learning to read the meter and use its features requires **practice**.

Additional Features of DVOMs

Because there are so many features on some of these meters, you look at the UNITS display at the side of the meter. This will tell you if you are looking at Volts, Ohms, Kilo-ohms, Hertz, Percent Duty Cycle, or if the Min-Max function is operating.

Min-Max Feature

Note which UNITS are displayed

Analog Bar Graph

Symbol	Prefix	Meaning	Automotive Use
M	Mega	X Million	None
K	Kilo	X Thousand	Ohms, Volt
		Single Unit	All
m	milli	X thousandth	Amps
μ	micro	X millionth	None

Fig. 3-6
L6521306

Digital Voltmeter

The most frequently used feature of a DVOM is the voltmeter. A voltmeter is useful to determine if there is voltage present at specific points in the circuit when diagnosing open circuit problems. By applying the series circuit voltage drop concept, it can also be used to quickly isolate the location of any high circuit resistance problem.

Measuring Open Circuit Voltage or Pin Voltage

Measuring Open Circuit Voltage or Pin Voltage:

1. Connect the **negative probe to ground at the component ground terminal or to a known good ground.**
2. Connect the **positive probe to the pin** you want to inspect

HINT

- If the meter is **auto-ranging**, fix the display to show only 1 decimal point. If the meter is **non auto-ranging**, use the 20V range.
- Remember that an open circuit voltage measurement tells you only **if there is a connection to B+**; it **DOES NOT** tell you how **much resistance** there is in the connection or circuit.

Measuring Open Circuit Voltage

This inspection can be made by backprobing the terminal, or from the front with the connector disconnected. If you have to probe from the front of the connector, **NEVER** insert the test probe into a female terminal.

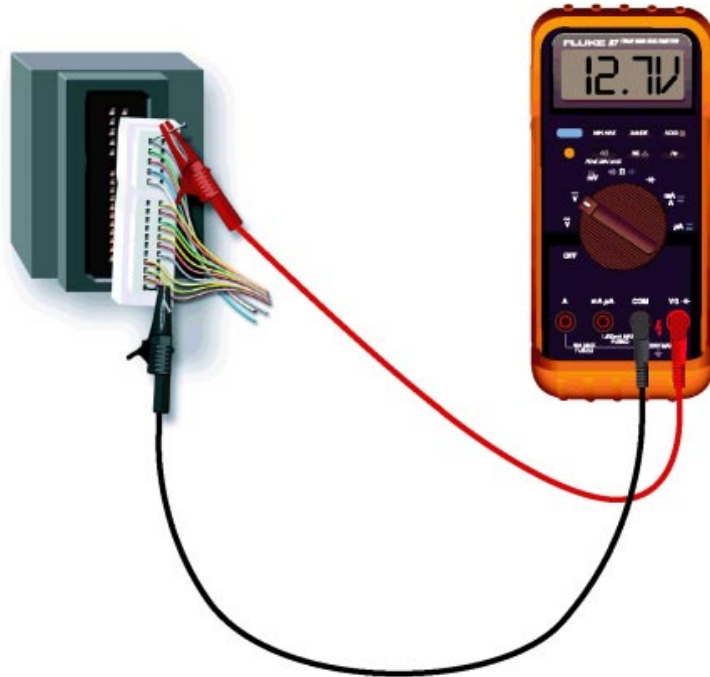

Fig. 3-7
L652f307

Voltage Drop Measurement

A **voltage drop** measurement is taken *dynamically* while the circuit is in operation.

1. Turn the circuit **ON**.
2. Connect the positive and negative probes of the meter in parallel to the component or section of the circuit you want to check.
 - By using the EWD, you can isolate portions of the circuit and check for unwanted resistances.
 - A measurement of 0 Volts can indicate two different conditions:
 - a. There is virtually no resistance in the part of the circuit you are checking.
 - b. The circuit is OFF or open; no current flow.

HINT

This is the most accurate way to detect a problem resistance in high amperage (above 3 or 4 amps) circuits. In these circuits, even a resistance of 1Ω or less can have a big effect on the load. Because the test is done while the circuit is operating, factors such as the amount of current flow and the heat generated will be taken into account.

Measuring Voltage Drop

Connect the voltmeter in parallel to the part of the circuit you want to check by backprobing the connector. Remember the load should be getting about the same as battery voltage **WHILE THE CIRCUIT IS OPERATING**.

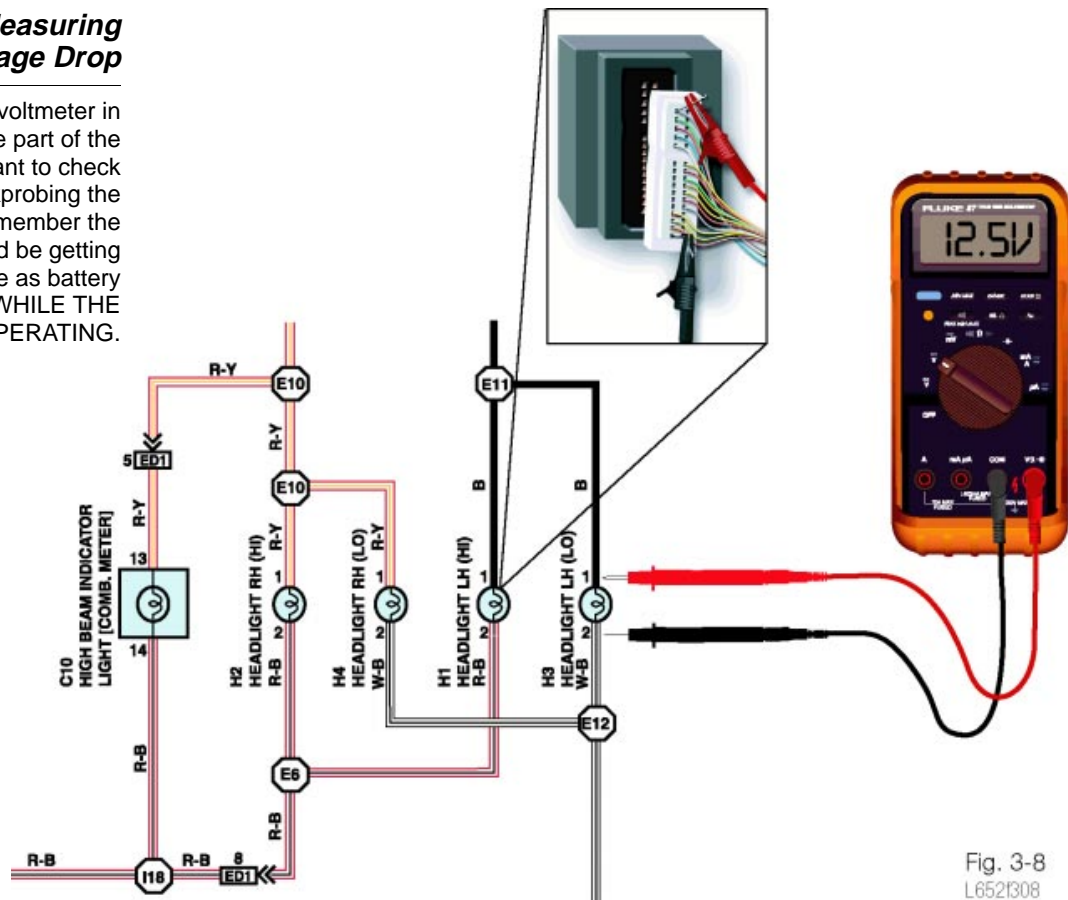

Fig. 3-8
L6521308

Digital Ammeter

Because Repair Manual and EWD specifications are usually in volts, the ammeter is not frequently used as a tool in body electrical diagnosis. It can, however, be a very effective tool.

The ammeter is typically used in:

1. **Starting and Charging System** inspection
2. **Diagnosing parasitic load problems.** A *parasitic load* is sometimes referred to as a “draw”, something that drains the battery while the car is parked overnight.

The ammeter can be used to dynamically test the condition of a circuit. But because amperage specs are not found in the RM or EWD for most circuits, and because ammeters cannot pinpoint the location of a problem like a voltmeter can, it is not frequently used in body electrical diagnosis.

HINT

If a component in a circuit is particularly difficult to access (such as the electric fuel pump), an amperage measurement of the circuit can be a good indicator of the circuit's condition. Because there are no specs given for this circuit, you will need to **measure the amperage draw of the same circuit on a known good vehicle**, and **compare the readings** to determine if you have a problem.

Diagnosing with an Ammeter

For the fuel pump, an ammeter can be put in series at the +B and Fp terminal (key ON, engine OFF). This operates the fuel pump and lets you check the amount of amperage the fuel pump is drawing. Compare this reading to a known good vehicle.

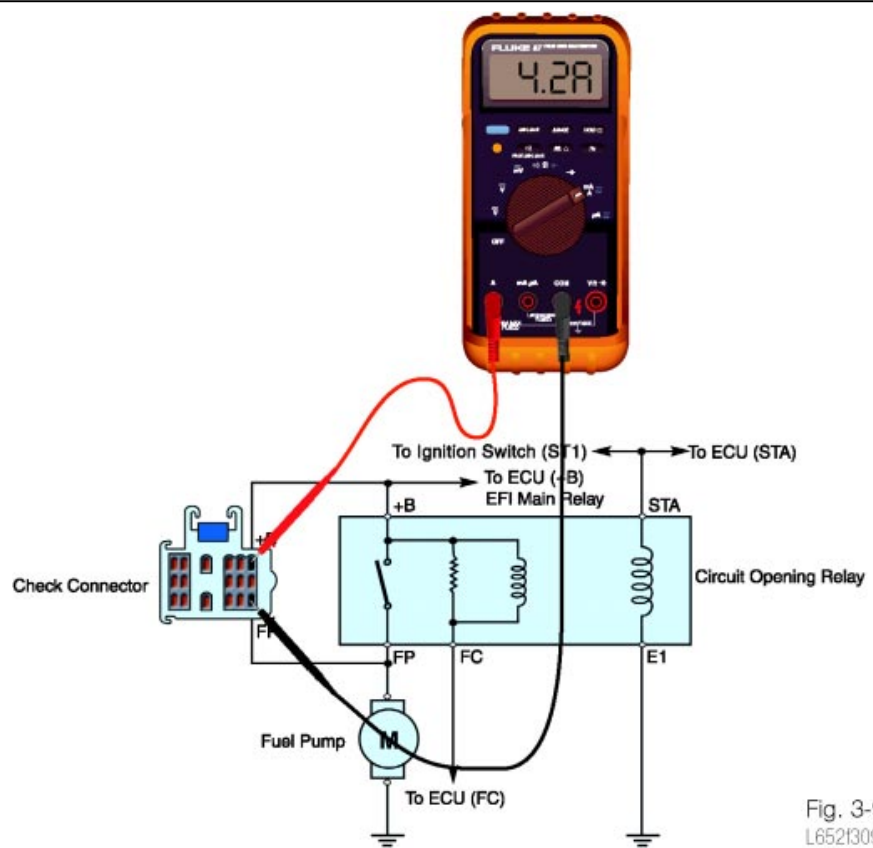

Fig. 3-9
L6521309

Types of Digital Ammeter

There are two types of ammeters: a *series type* and *clamp type*.

A **series type ammeter** is the type of meter that is built into every DVOM. This meter is designed to measure relatively small current flows (below 10A). Most meters measure in either *milliamps (mA)* or *Amps (A)*. Before connecting the meter into the circuit, make sure the circuit draw is within what your meter can handle. It is a good practice to initially set the meter to the highest range available, and lower the range while the current is being measured. Most ammeters are fuse protected to prevent damage from short-to-grounds or overload conditions. The series type ammeter is best suited for measuring current flows below 1A.

We have been using **clamp type ammeters** for years on starting/charging system testers such as the Sun VAT- 40/60. This type of ammeter is also available as an accessory that you can use with any DVOM. These battery-powered clamp type ammeters (sometimes referred to as “inductive-type” ammeters) measure current flow by sensing the strength of the magnetic field produced around the wire while current flow is present. These clamps then convert this amperage reading into a **voltage** which is read with the **DVOM set to measure millivolts**. Due to a lack of accuracy below 1 amp, these accessories are best suited for any amperage measurement except normal parasitic loads. It can be used to troubleshoot a high parasitic load problem if the “draw” is above 0.5A, depending on the model of “amp clamp” you are using.

The correct connections for each type of ammeter are shown in Figure 3-10.

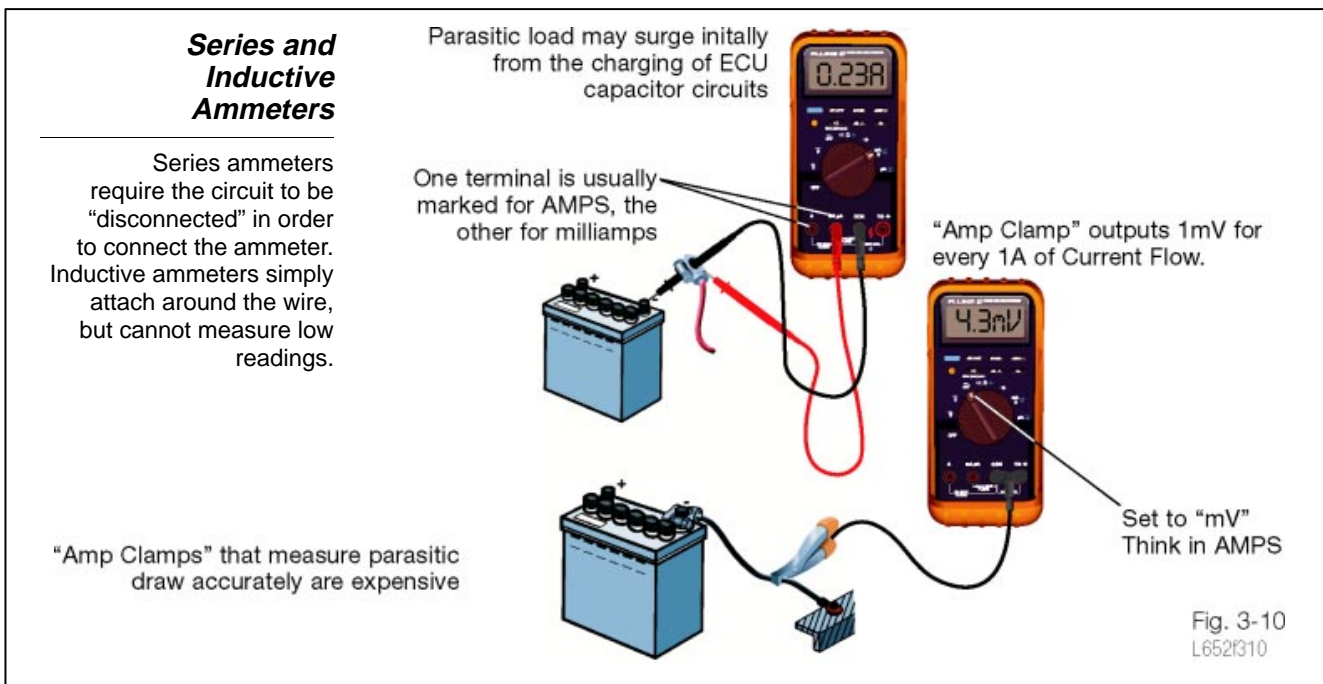

Digital Ohmmeter

An ohmmeter measures the amount of electrical resistance between two points. The digital ohmmeter has several significant advantages over its analog counterpart:

- Easier to read—the sweep doesn't go “backwards”
- “Zero” resets automatically
- Extremely accurate

Digital Ohmmeter Display

If you are using the meter in auto-ranging mode, be sure to look at the units (K Ω or Ω) at the side of the display or on the range selection knob.

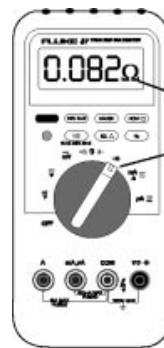

Look at the Display or the Range Selector

Fig. 3-11
L6521311

Additional Features - Diode Check

When connecting an ohmmeter, make sure that the circuit or component is isolated from parallel branches or other voltage sources. Most good quality meters are “forgiving” when accidentally connected to voltage, but analog meters and low priced DVOMs may not be.

In the past, an ohmmeter was commonly used to check diodes. The operation of the diode could be verified by checking for continuity in one direction, and for no continuity in the other. However, the voltage that a digital ohmmeter uses to make its resistance measurement is usually less than 0.2V. This low voltage is not enough to “forward bias” the diode, so the diode will show no continuity in either direction.

NOTE

Most good quality DVOMs have a diode check function. This function (on the better meters) will tell you the *forward bias voltage drop* of the diode—the amount of voltage required to turn ON the diode so that current will flow through it. **For the silicon diodes found on the car, this voltage should be around 0.5V.**

Diode Check

Use the diode check function to check the condition of a diode. Besides in the alternator, diodes are used frequently in the wiring harness to provide circuit isolation. Look for about 0.5V with the diode check function.

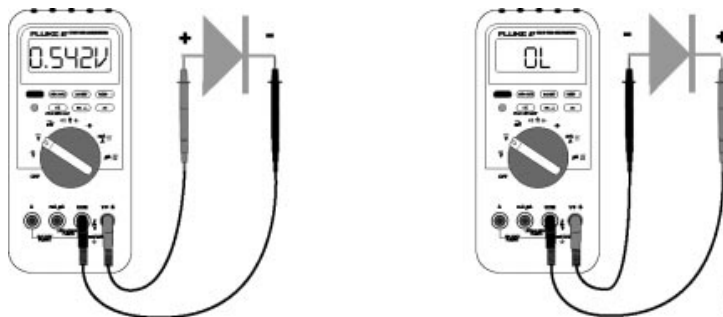
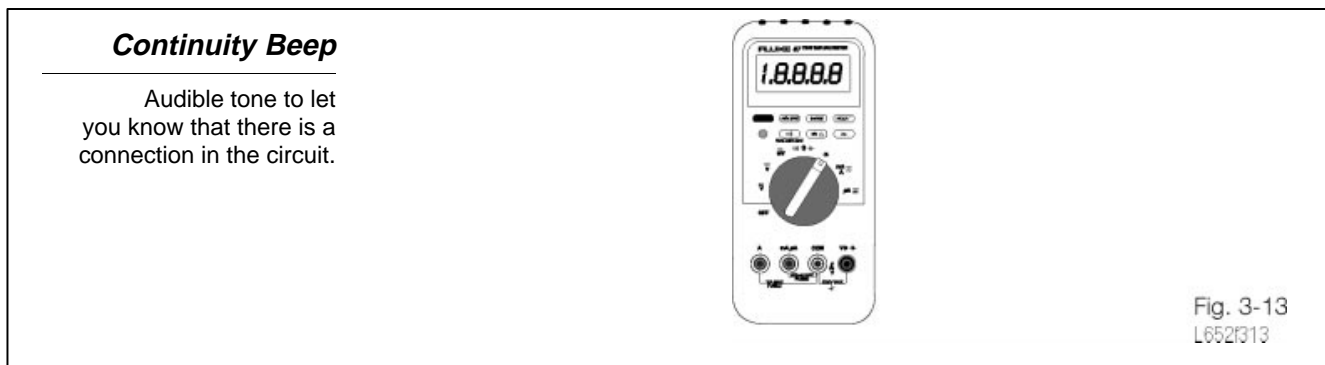

Fig. 3-12
L6521312

Some low priced meter's diode check function do not measure the forward bias voltage drop. Instead, these meters simply raise the voltage used by the ohmmeter to allow a check for continuity in one direction and no continuity in the other. The number on the display is **not** a voltage drop.

Additional Features - Audible Continuity Beep

When working under the instrument panel or in an area where the face of the meter is not easily visible, the audible continuity beep is helpful. The specifications for this feature vary between meter manufacturers. Most meters will “beep” whenever there is a less than a specified amount of resistance measured. (This can mean **within double the range** selected or could be just 5 - 10% of the range selected on the meter.) On many meters, the “beep” feature also works with the voltmeter.



Ohmmeter Common Mistakes

- **Zero Ohms:** Don't confuse 0Ω with ∞ or OL, An *infinite amount* of resistance means that there is an OPEN in the circuit—no current flow can get through. **Zero ohms indicates perfect continuity, no resistance to current flow.**
- **Placement of the Decimal Point:** Auto-ranging meters automatically change the display from ohms (Ω) to kilo ohms (K Ω).

CAUTION

Never test an ECU directly with an ohmmeter. The measurement made will be inconclusive at best, and could cause damage. The correct method for using the ohmmeter is shown in the diagram below.

